



National Analytical Management Program (NAMP)
U.S. Department of Energy Carlsbad Field Office

Radiochemistry Webinars

Environmental/Bioassay Radiochemistry Series

Alpha Spectroscopy



*In Cooperation with our
University Partners*



Meet the Presenter...

Dr. Ralf Sudowe

UNLV

Dr. Ralf Sudowe has extensive experience in the area of nuclear and radiochemistry, particularly in the development of radioanalytical separations for actinide and transactinide elements, as well as fission products. He is an Associate Professor of Health Physics and Radiochemistry at the University of Nevada Las Vegas. He received a M.S. degree in Chemistry from the Philipps-University Marburg in Germany in 1995, and a Ph.D. in Nuclear Chemistry from the same institution in 1999. Dr. Sudowe spent two years as Visiting Postdoctoral Fellow in the Nuclear Science Division at Lawrence Berkeley National Laboratory and then worked for five years as Staff Scientist in the Nuclear Science and Chemical Sciences Division at LBNL before joining the faculty at UNLV in 2006. He is a member of the American Chemical Society, the American Nuclear Society, and the Health Physics Society.



At UNLV, Dr. Sudowe teaches courses in radioanalytical chemistry, radiation detection, and environmental health physics and radiation biology, as well as laboratory courses in radiochemistry and radiation detection instrumentation. His research focuses on the development and optimization of advanced radioanalytical methods for environmental monitoring, nuclear forensics and safeguards, and emergency response. The goal is to make radioanalytical methods available that have lower detection limits for the radionuclides of interest, facilitate the fast analysis of a large number of samples, and allow assay of unusual sample matrices such as urban rubble and process streams. The research utilizes a variety of modern analytical tools to obtain better understanding of the fundamental properties of the separation process and to elucidate the role that interfering elements have on the technique. Dr. Sudowe also studies the chemical and nuclear properties of transactinide elements and is involved in target preparation and cross section measurements for stockpile stewardship science.

Contact Information

Phone: +1 (702) 895-5964

Email: ralf.sudowe@unlv.edu

Alpha Spectroscopy

Dr. Ralf Sudowe

*Associate Professor of Health Physics and Radiochemistry
University of Nevada Las Vegas*

UNLV



**National Analytical Management Program (NAMP)
U.S. Department of Energy Carlsbad Field Office**

TRAINING AND EDUCATION SUBCOMMITTEE



Disclaimer

- Certain products and manufacturers are mentioned during this presentation for the purpose of fostering understanding.
- Reference to these commercial products and manufacturers in this presentation does not constitute recommendation or endorsement of the products.

Alpha Spectroscopy

- Alpha spectroscopy is a widely used technique for the identification and quantification of alpha-emitting radionuclides.
 - Naturally occurring alpha emitters
 - Transuranium elements, special nuclear materials
- It is characterized by high efficiency, low background and low detection limits.
- It can be applied for the assay of a variety of samples.

Alpha-Emitters

BROOKHAVEN
NATIONAL LABORATORY

Radionuclide Data Center

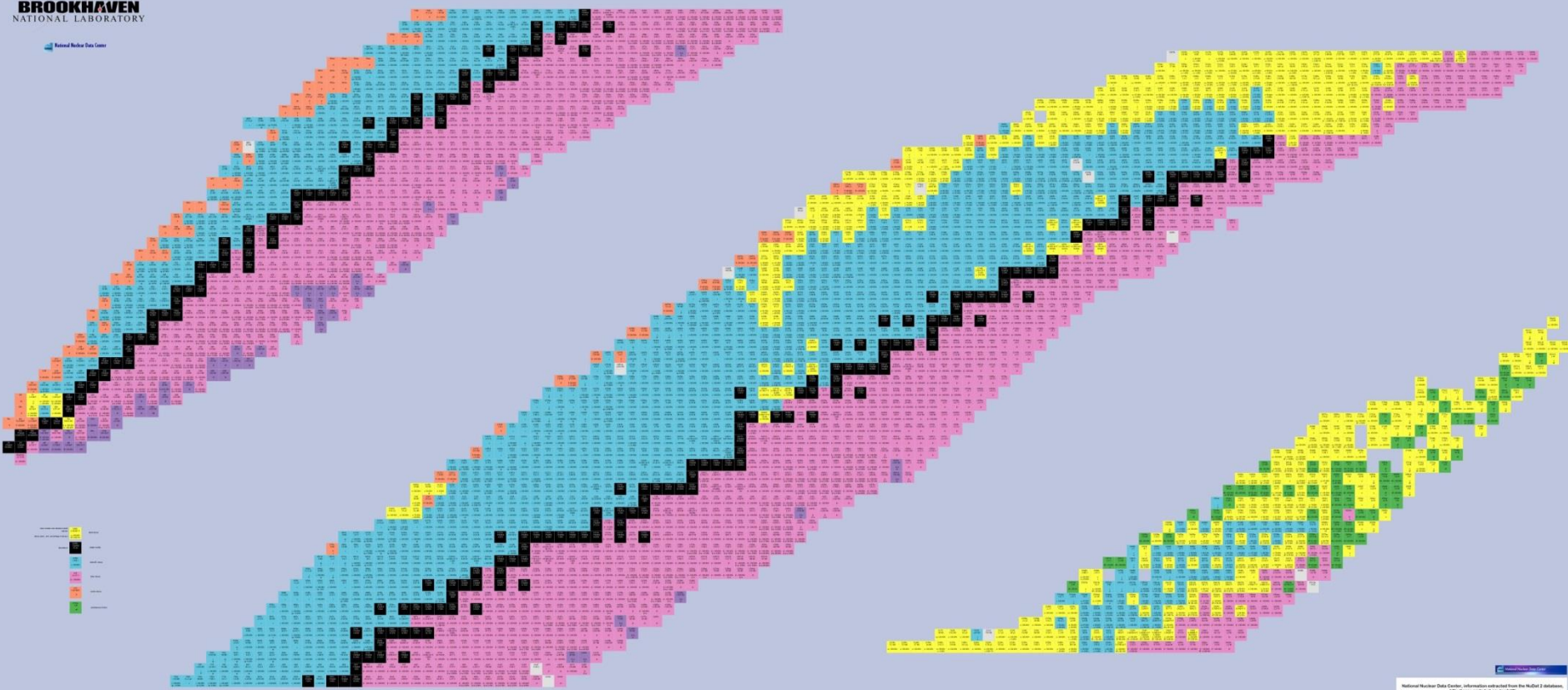

National Radionuclide Data Center. Information extracted from the NuDat 2 database.
© 2016 Brookhaven National Laboratory
 Users should feel free to use the information from NuDat 2 tables and plots in their work, reports, presentations, articles and books.

Alpha Spectroscopy

- Alpha spectroscopy typically requires the separation of the element of interest from the bulk sample.
 - Exception: Limited analysis of air filters
- Typically, every element is isolated individually.
- Then one source is prepared for each element of interest.

Advantages

- Applicable to a large number of radionuclides.
- High sensitivity/low detection limit.
 - High intrinsic efficiency
 - Low intrinsic background
 - Favorable branching ratios
 - Transitions are grouped in a narrow energy range
 - Fairly insensitive to beta and gamma radiation
- Comparably low capital cost.

Disadvantages

- Subject to severe attenuation effects.
 - Limited energy resolution
- Requires substantial sample processing.
 - Sophisticated chemical separations necessary
 - Time/labor intensive
 - Requires chemical laboratory

Detection Technique

Detection Technique

Solid-State Semiconductor Detector

Frisch-Grid Ionization Chamber

Photon-Electron Rejecting Alpha Liquid Scintillation (PEARLS)

Microcalorimetry

Detector Setup



Detectors

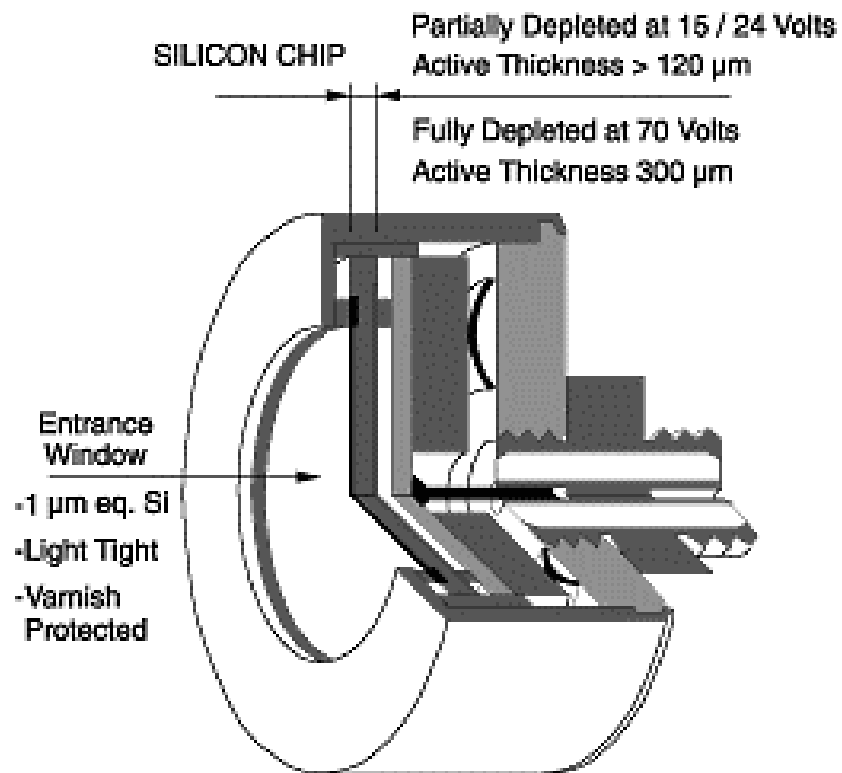

Detectors

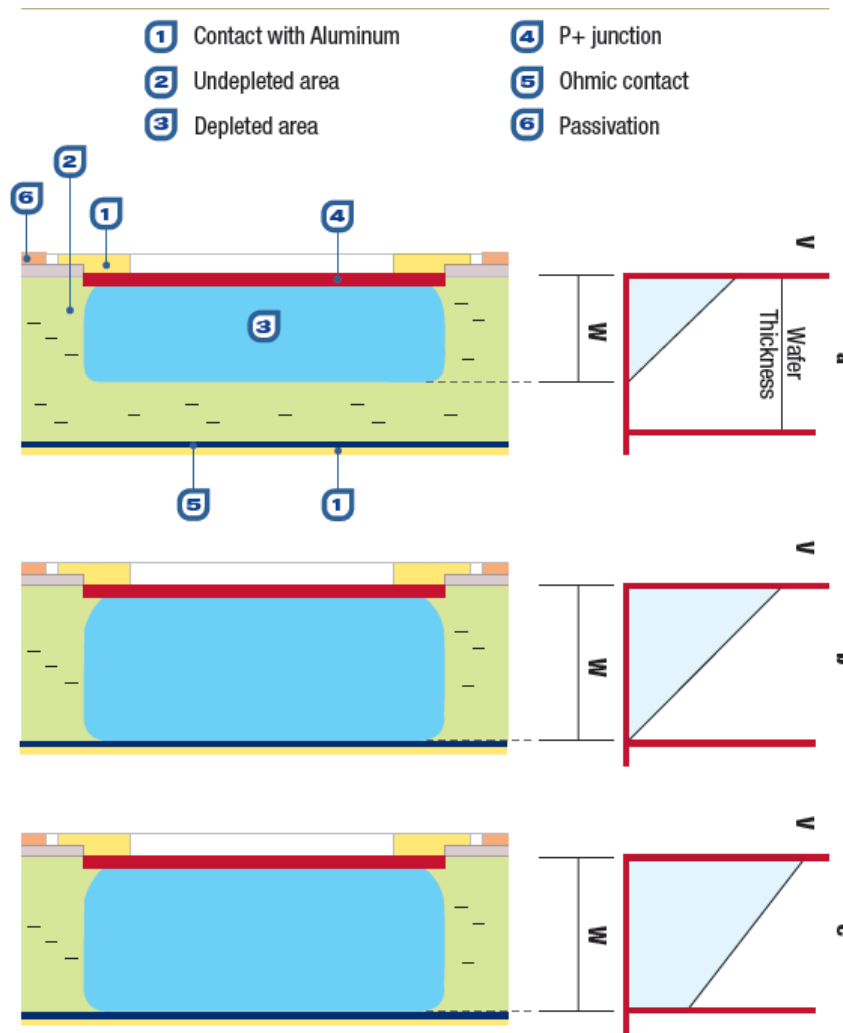
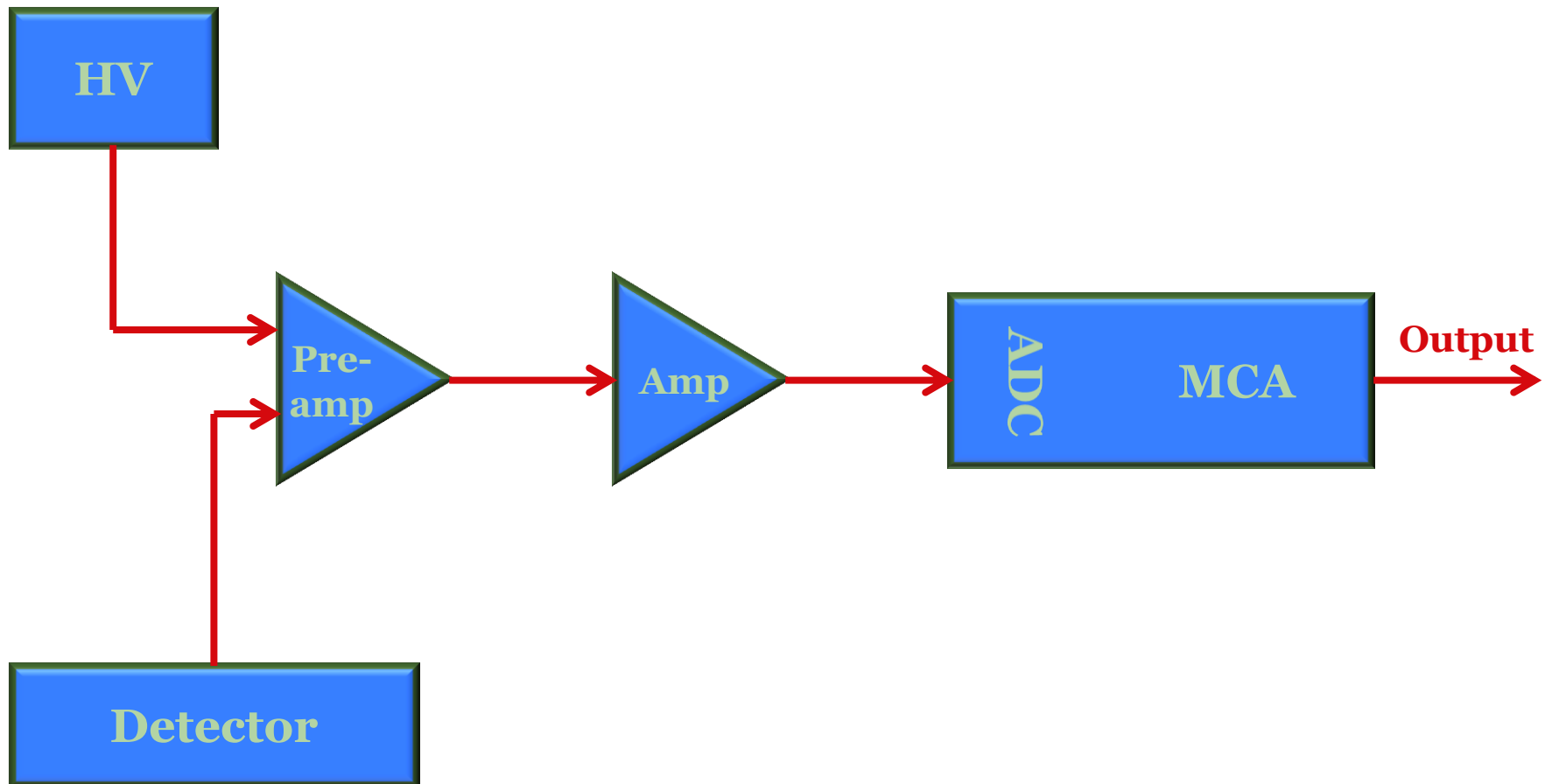

Figure 1

Thickness W of the depletion layer as a function of applied bias

- partially depleted mode
- fully depleted mode
- fully depleted mode with overvoltage

Detector Setup



Alpha Particle Spectroscopy

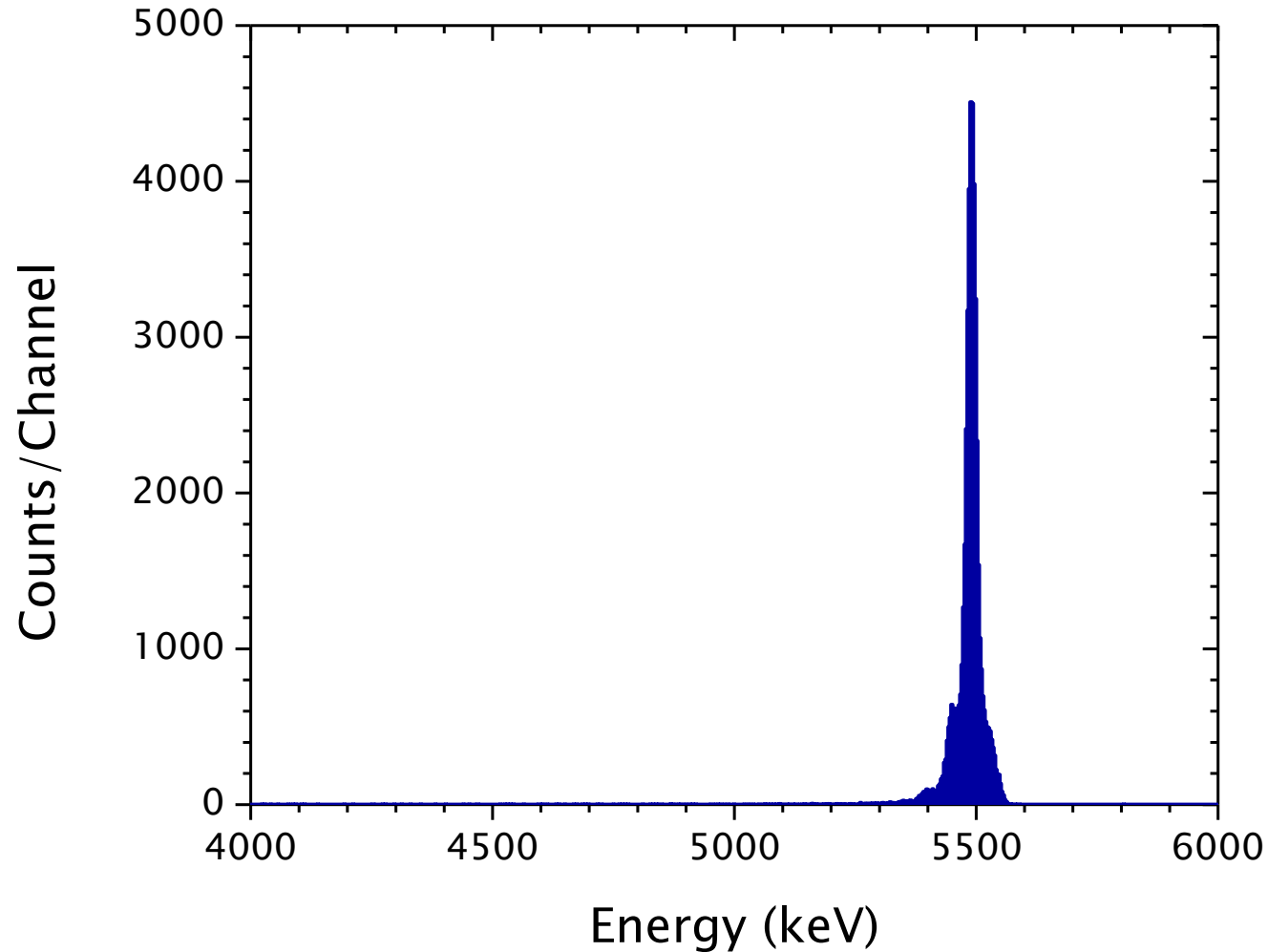

Alpha Particle Spectroscopy

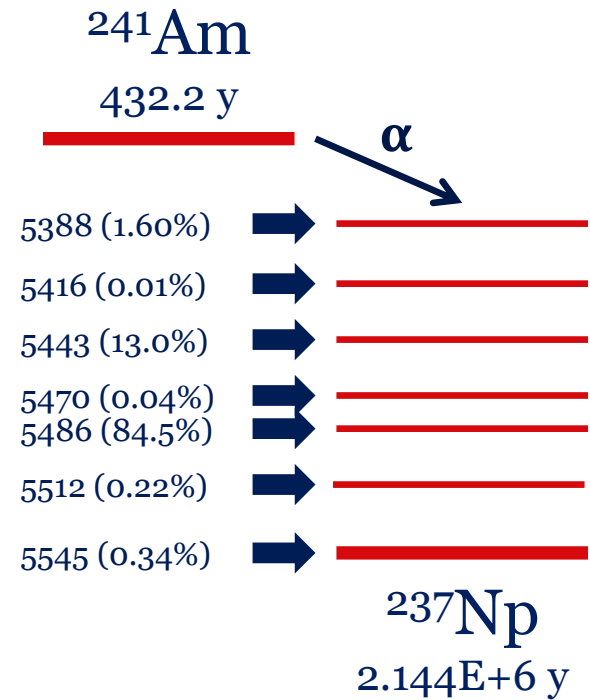
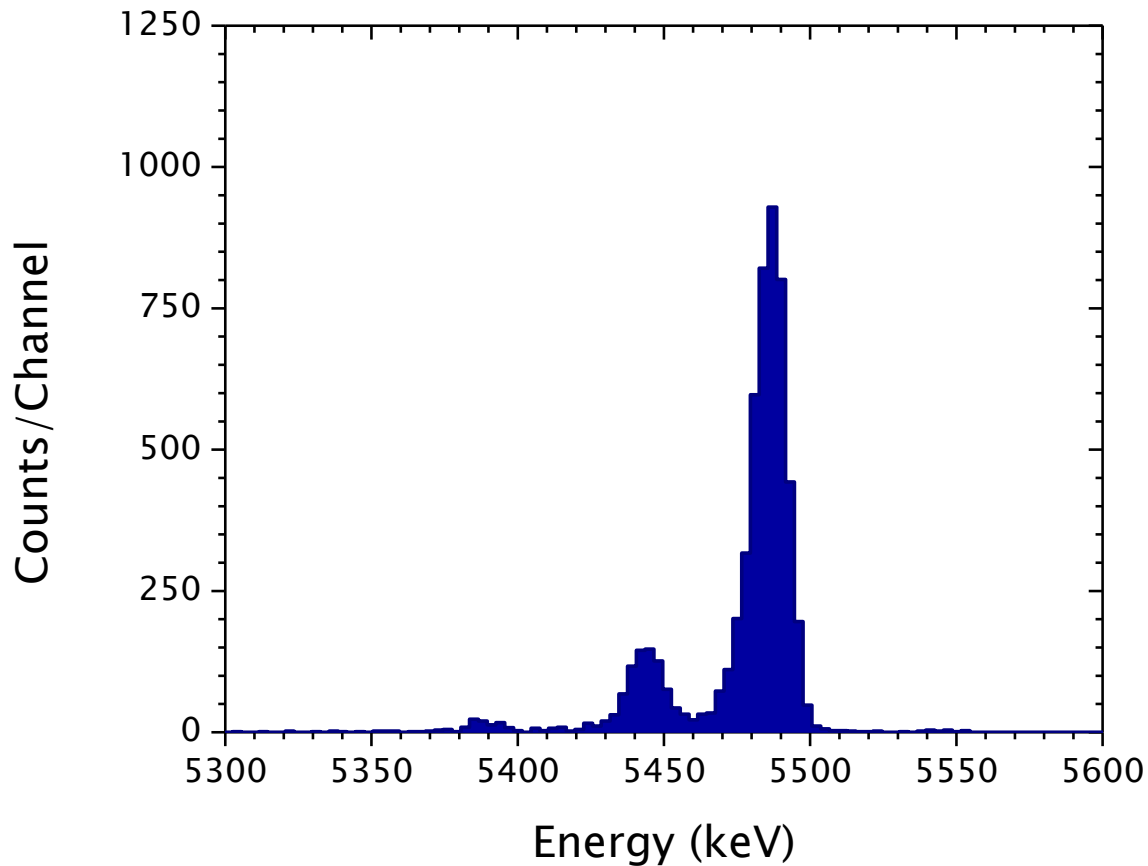

Effect of Sample Thickness

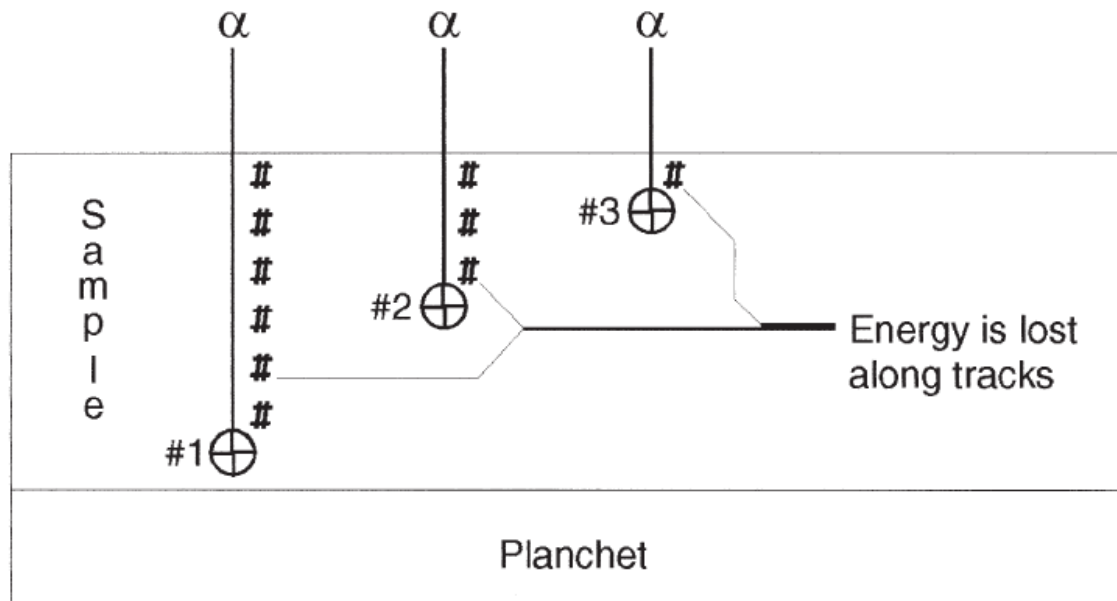
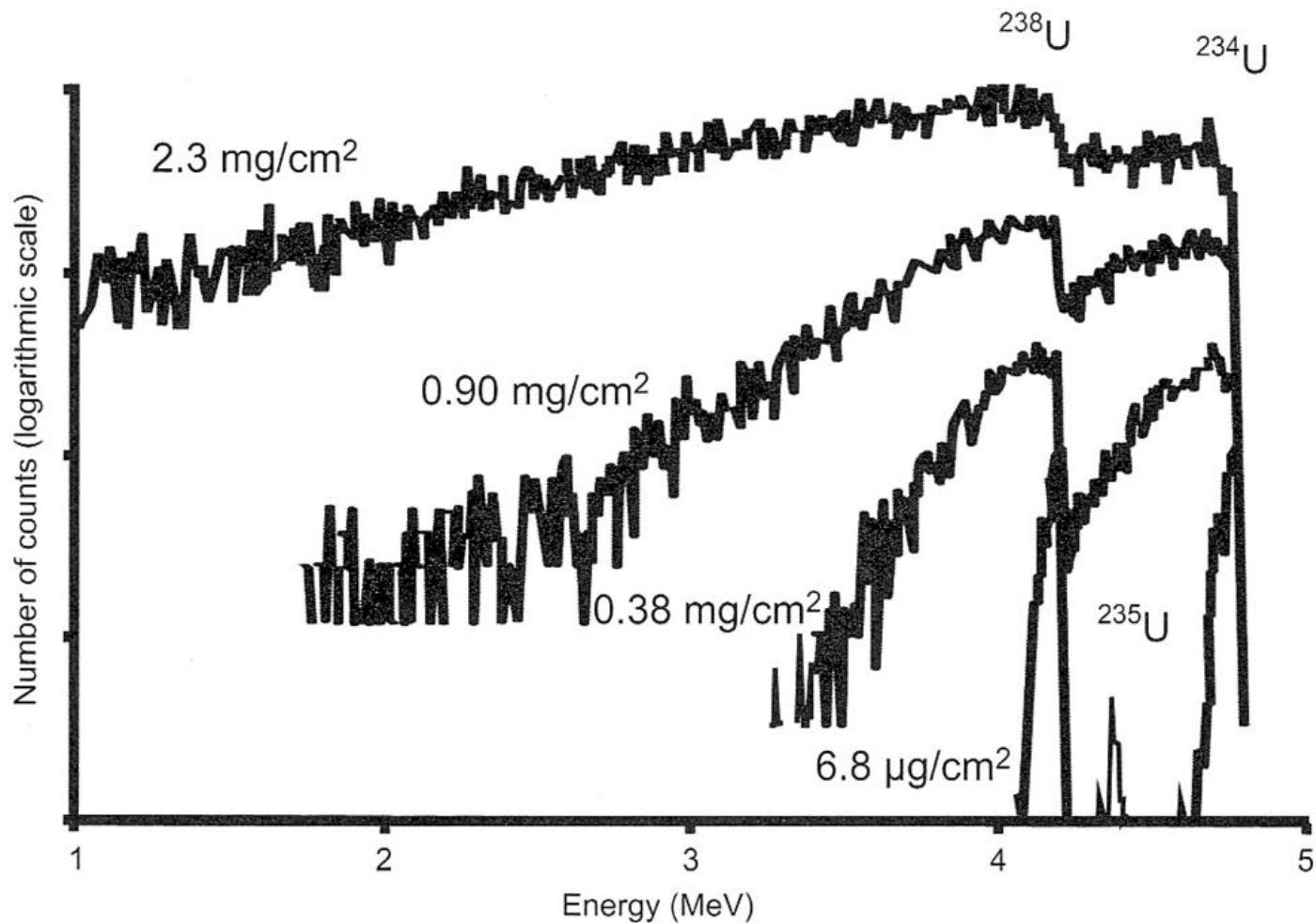

FIGURE 4.33 Three atoms of an alpha-emitting nuclide (labelled 1, 2, and 3) are deposited at different depths within the thickness of the sample. The energy of the alpha particle from the atom labelled #1 will be degraded more than that of #2, which in turn is degraded more than that of #3. Thus the observed energy of the alpha particles from a thick (monoenergetic) sample will have a distribution of energies reflecting the thickness of the sample (as well as due to straggling).

Effect of Sample Thickness



Source: Pöllänen, R., Siiskonen, T., Vesterbacka, P., *High-resolution alpha spectrometry from thick sources*, Radiation Measurements **39**, 565 (2005)

Effect of Absorption

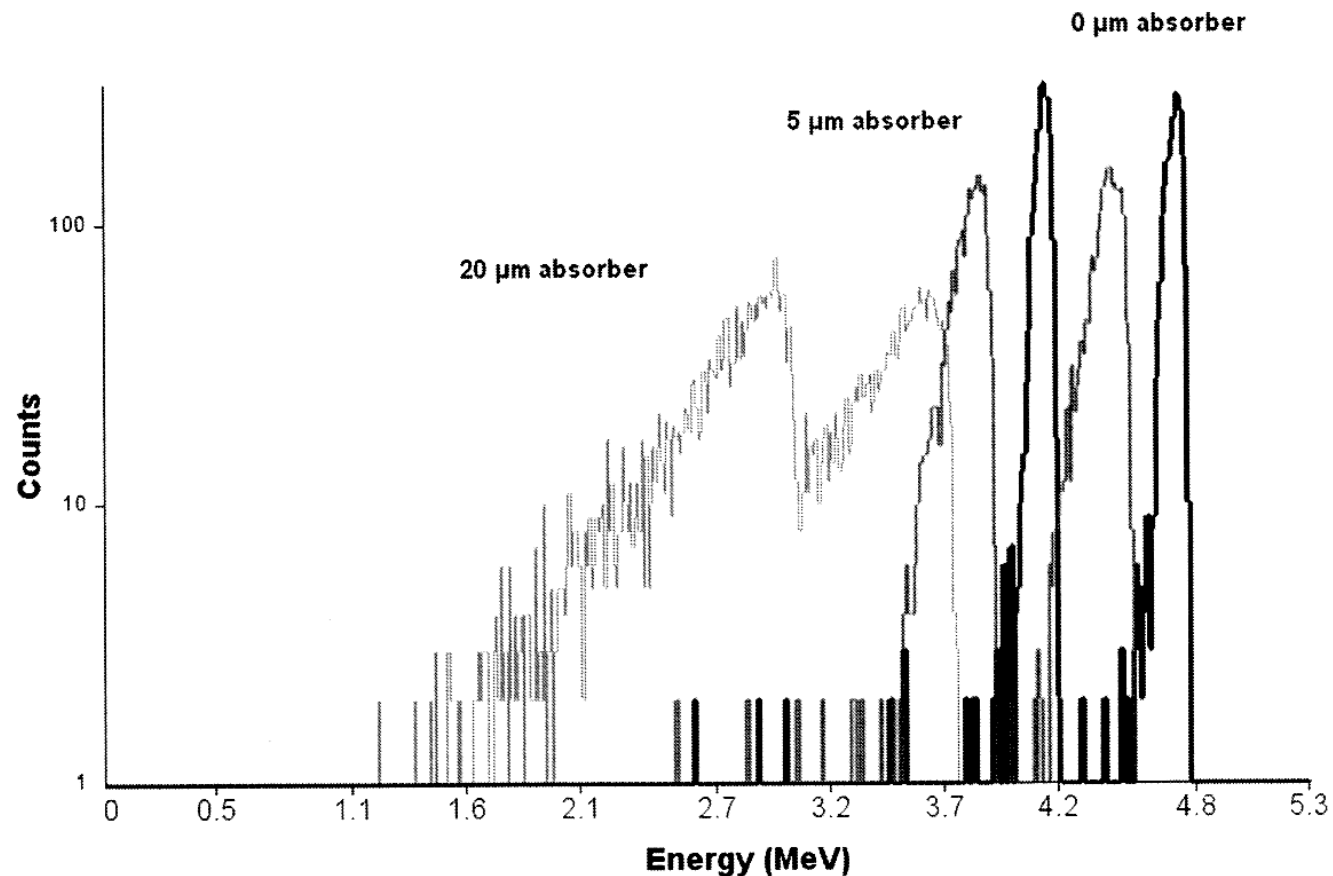

Effect of Self-Absorption

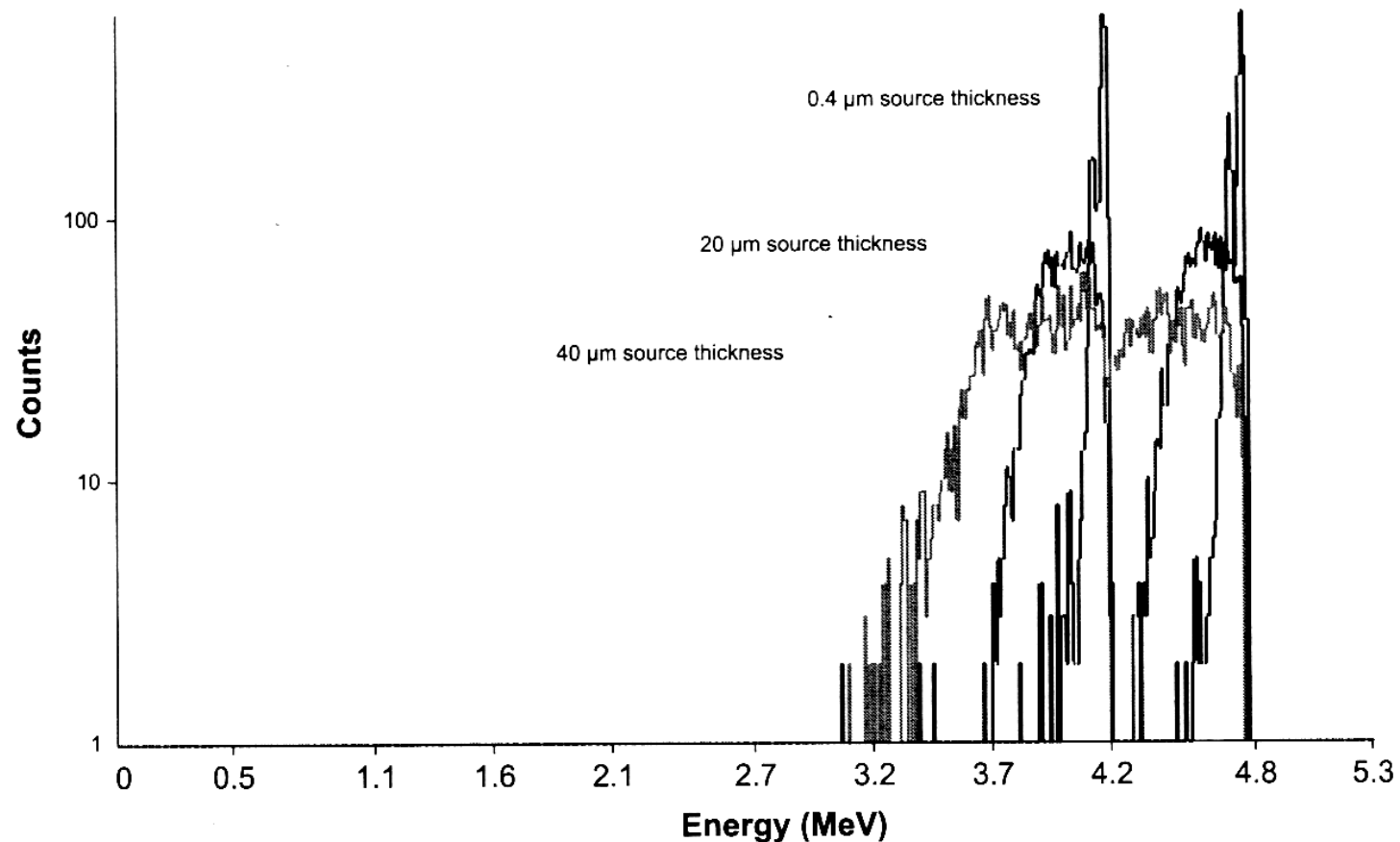

Counting Efficiency

- The intrinsic efficiency of the semiconductor detectors used for alpha spectroscopy is typically 100%.
- The absolute efficiency is therefore governed by the solid angle between the source and the detector.
- This assumes that the source is homogeneous.

Counting Efficiency

- The absolute efficiency ε_{abs} for a point source is given by:

$$\varepsilon_{abs} = \frac{1}{2} \cdot \left(1 - \frac{H}{\sqrt{H^2 + 4R_D^2}} \right)$$

where R_D = Radius of the detector

H = Distance between source and detector

Counting Efficiency

- However, in most cases the source cannot be represented as a point source.
- In such cases the absolute efficiency ε_{abs} can be approximated as:

$$\varepsilon_{abs} = \frac{1}{2} \cdot \left[\frac{R_D^2}{D \cdot (D + H)} \right] - \frac{3}{16} \cdot \frac{R_S^2 \cdot R_D^2 \cdot H}{D^5} + \frac{5}{32} \cdot \frac{R_S^4 \cdot R_D^2 \cdot H}{D^9} \cdot \left[H^2 - \frac{3}{4} \cdot R_D^2 \right]$$

Counting Efficiency

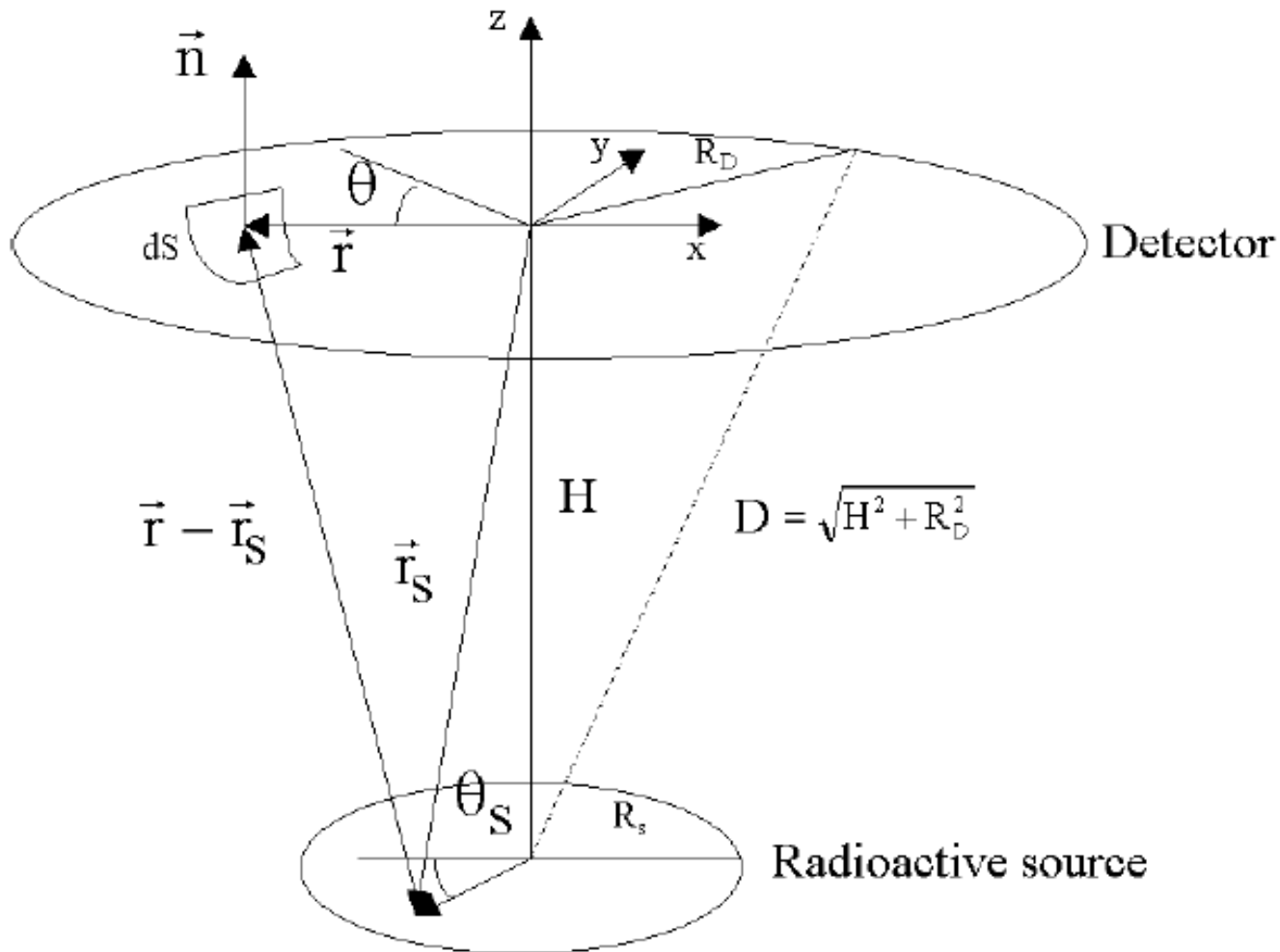

Counting Efficiency

- Typical counting efficiencies for a source with a diameter smaller than the detector are 20-40%.
- This assumes a source diameter of 10-15 mm and a detector area of 300-600 mm².
- As the distance between source and detector increases, the efficiency will decrease.
- The efficiency will also fall if the diameter of the source becomes larger than that of the detector.

Counting Efficiency

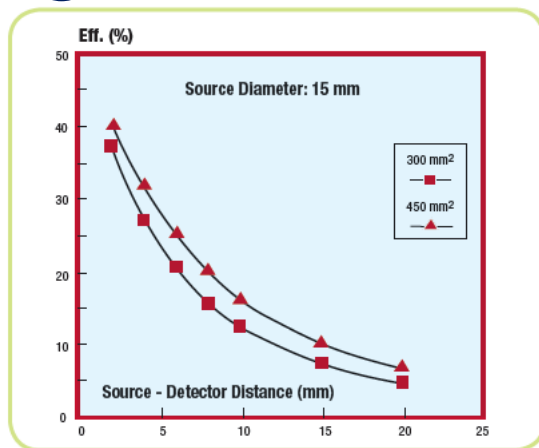

Figure 2
Geometric efficiency as a function of source-detector distance for a circular 15 mm diameter source coaxial with the detector.

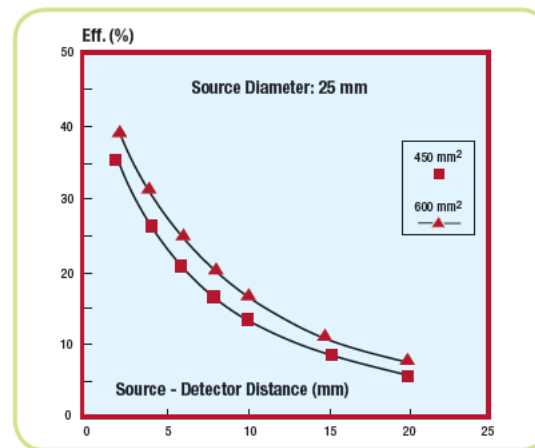

Figure 3
Geometric efficiency as a function of source-detector distance for a circular 25 mm diameter source coaxial with the detector.

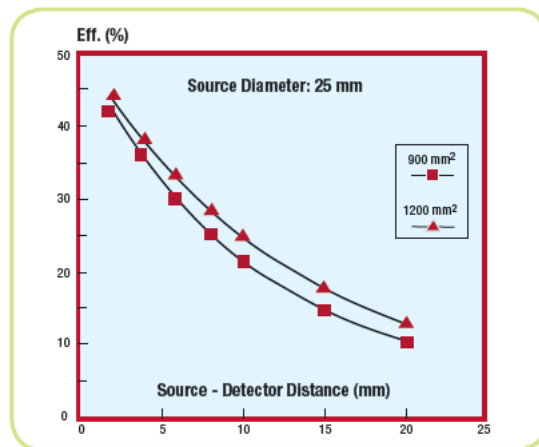

Figure 4
Geometric efficiency as a function of source-detector distance for a circular 25 mm diameter source coaxial with the detector.

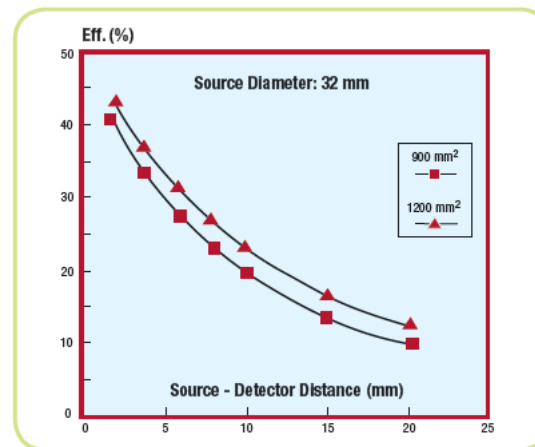
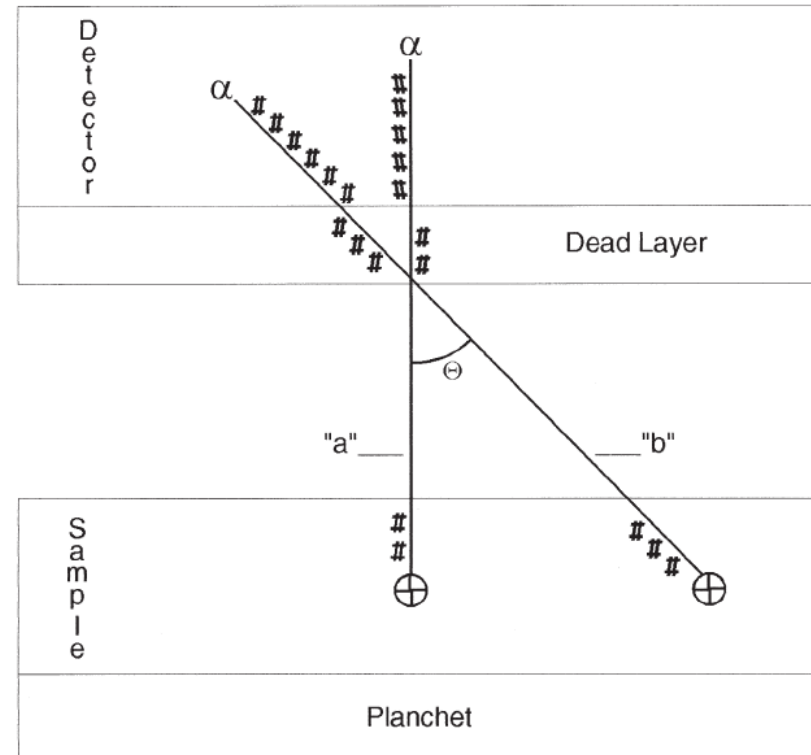
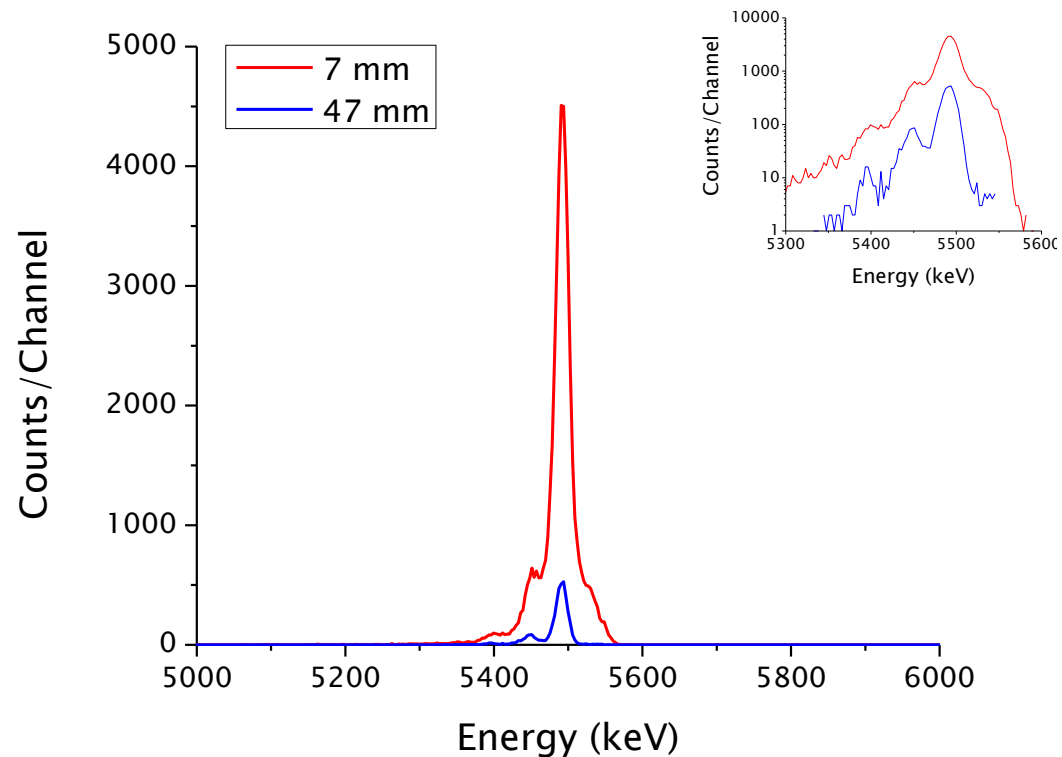

Figure 5
Geometric efficiency as a function of source-detector distance for a circular 32 mm diameter source coaxial with the detector.

Effect of Source Distance



Effect of Source Distance

- The difference in the track length of a particle traveling along path a versus path b is given by:

$$\Delta = \text{Difference in track length} = (d + t) \cdot \left(\frac{1}{\cos \theta} - 1 \right)$$

where d = thickness of the dead layer (window) on the detector

t = thickness of the sample

θ = acceptance angle of the detector

Effect of Source Distance

- Peak broadening can therefore be reduced by:
 1. Minimizing the dead layer d on the detector
 2. Minimizing the thickness t of the sample
 3. Minimizing the acceptance angle θ of the detector

Effect of Detector Size

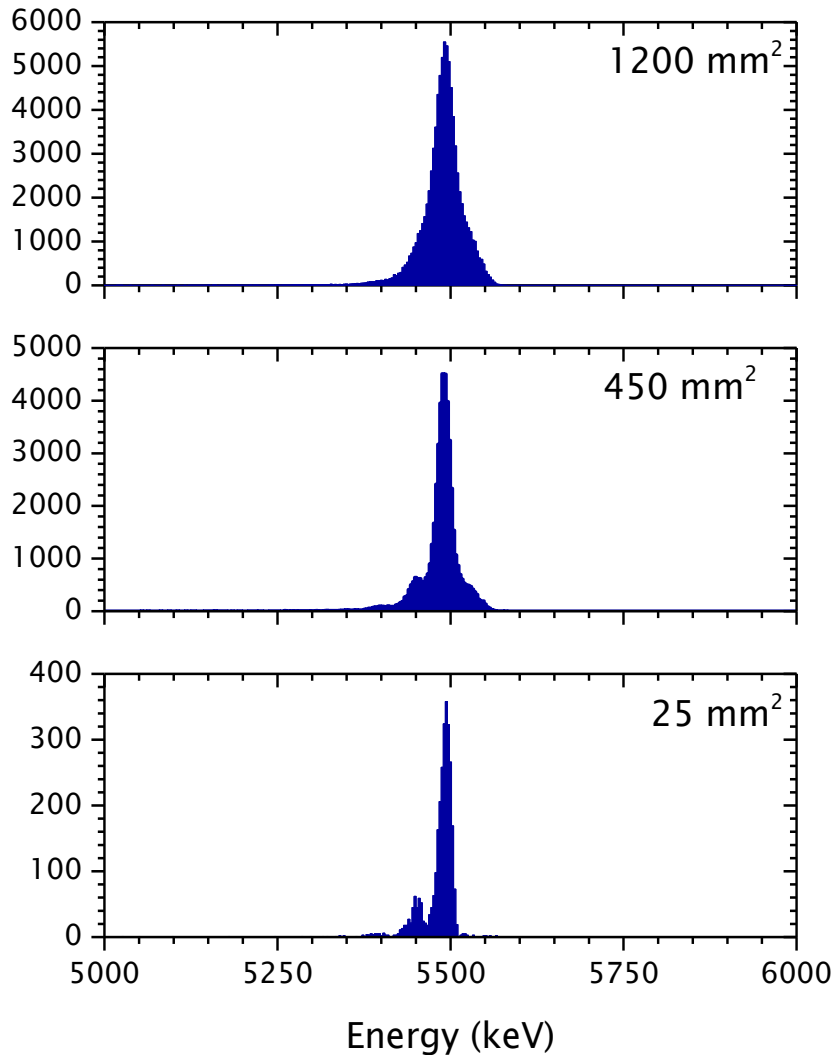

Active Area (mm ²)	Guaranteed Max. Resolution (keV FWHM)
25	12 14
450	17 21
1200	35 42

Effect of Detector Size

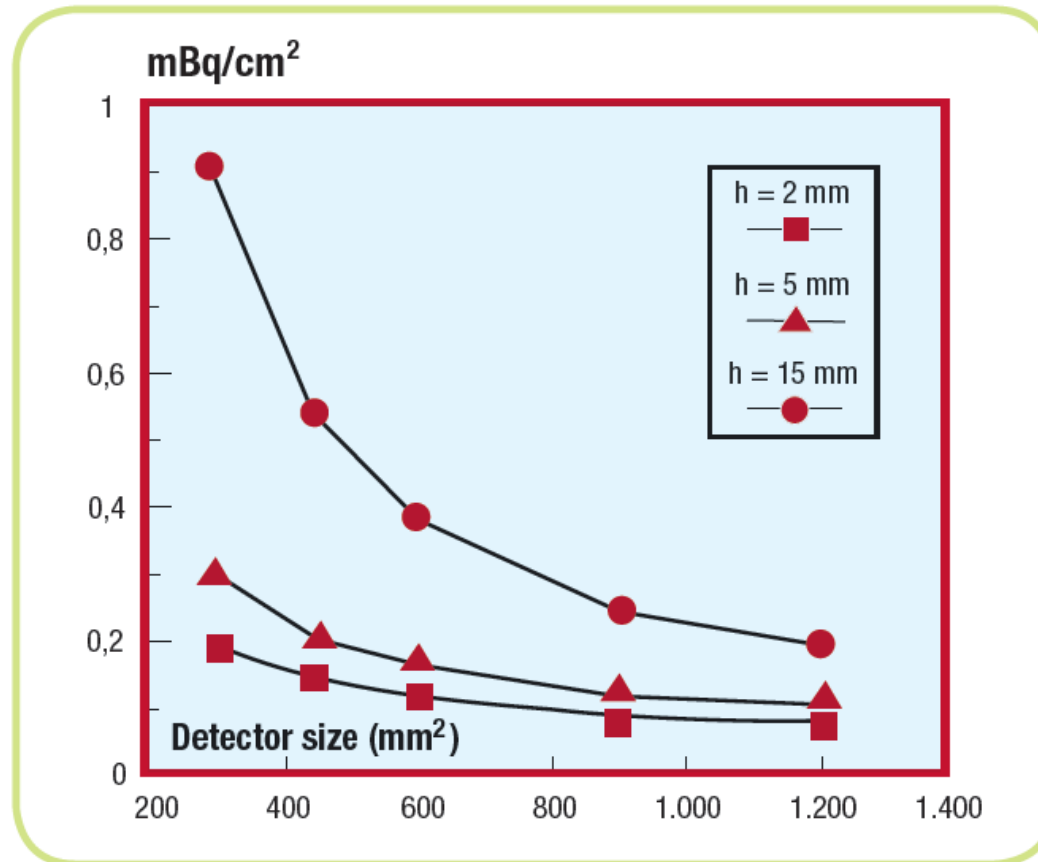

Figure 9
Specific minimum detectable activity as a function of detector size for three different values of source-detector distance h .

Background

- Background in alpha spectrometry is mainly due to electronic noise and contamination.
- The pulse signal from alpha decay is typically significantly larger than the electronic noise.
- They can therefore easily be distinguished through pulse height discrimination.
- The background of a new spectrometer can be as low as $10^{-5} - 10^{-6}$ cps.
- This results in a detection limit of 1 mBq.

Contamination

- Sputtering of radioactive material from the source can result in detector contamination.
- This typically happens if the source material is only loosely bound to the substrate.
- The process is further facilitated by the applied vacuum.
- However, this type of contamination can be removed by cleaning the detector.

Recoil Contamination

- The alpha decay imparts a certain momentum to the recoiling nuclei.
- This can cause the nucleus to be removed from the source.
 - Especially important for thin sources
- These atoms can attached themselves to the walls of the alpha chamber or the detector.
 - Difficult to remove
- This will result in an increased background.

Recoil Contamination

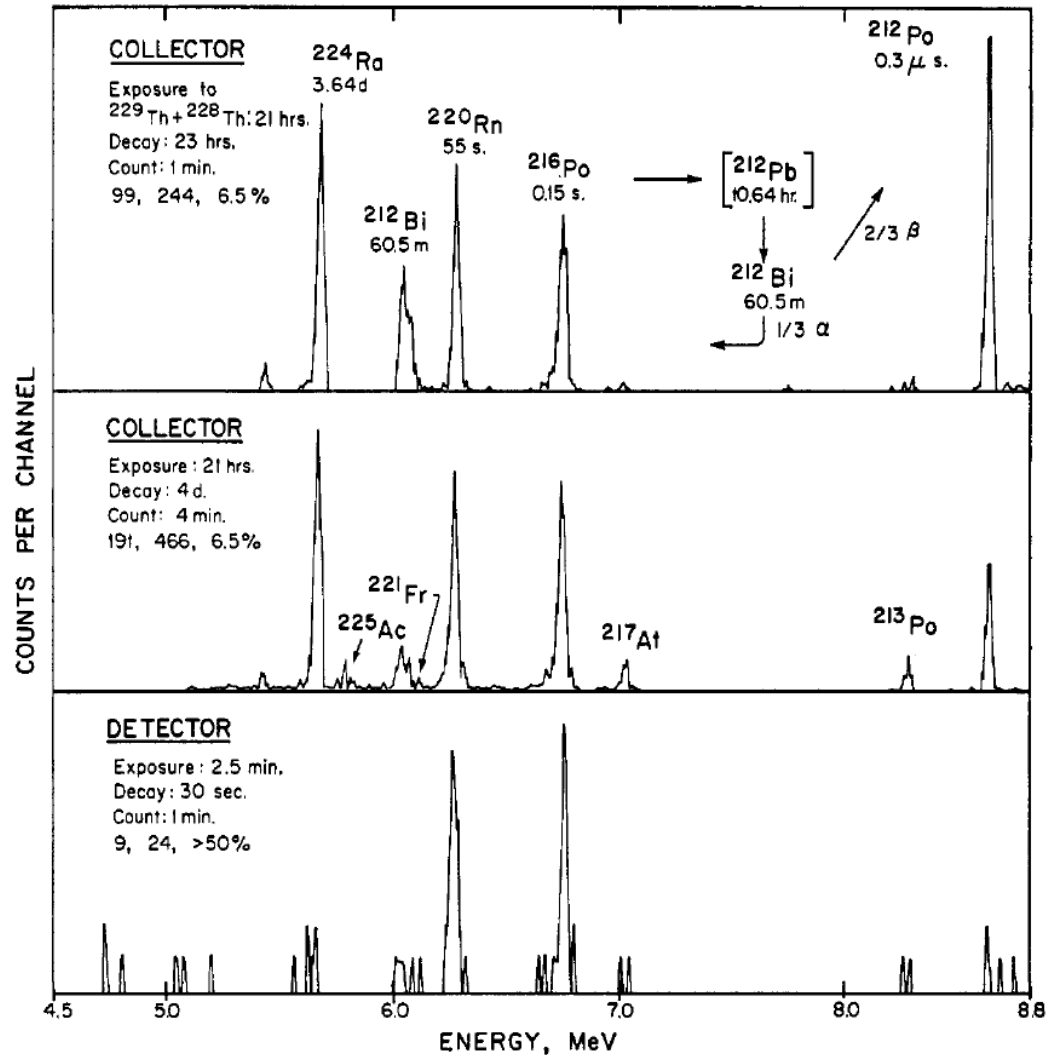

Source: Sill C.W., Olsen D.G., *Sources and prevention of recoil contamination of solid state alpha detectors*, Analytical Chemistry **42**, 1596 (1970)

Recoil Contamination

- Recoil contamination can be prevented by:
 - Creating an air barrier in the chamber
 - Twelve mg/cm² air will reduce recoil contamination by a factor of 1000
 - Applying a negative bias to the source holder
 - Covering the source with a thin foil

Recoil Contamination

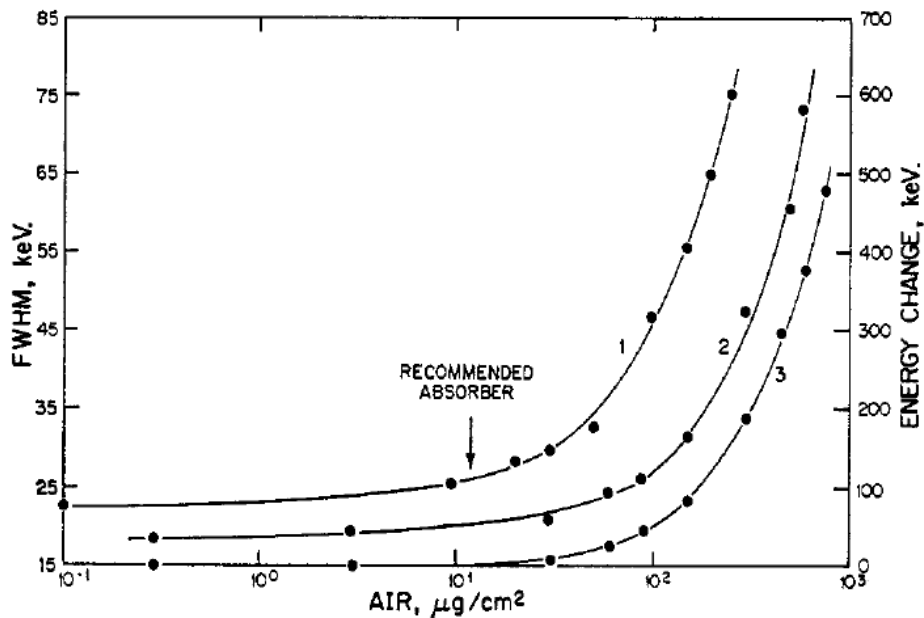

Figure 13. Change in resolution and apparent energy of ^{210}Po with increasing air pressure

Curve 1. Resolution obtained with a source-to-detector distance of 0.64 cm (top shelf) (left ordinate)

Curve 2. Resolution obtained with a source-to-detector distance of 1.92 cm (3rd shelf) (left ordinate)

Curve 3. Shift in peak position or apparent energy. (right ordinate)

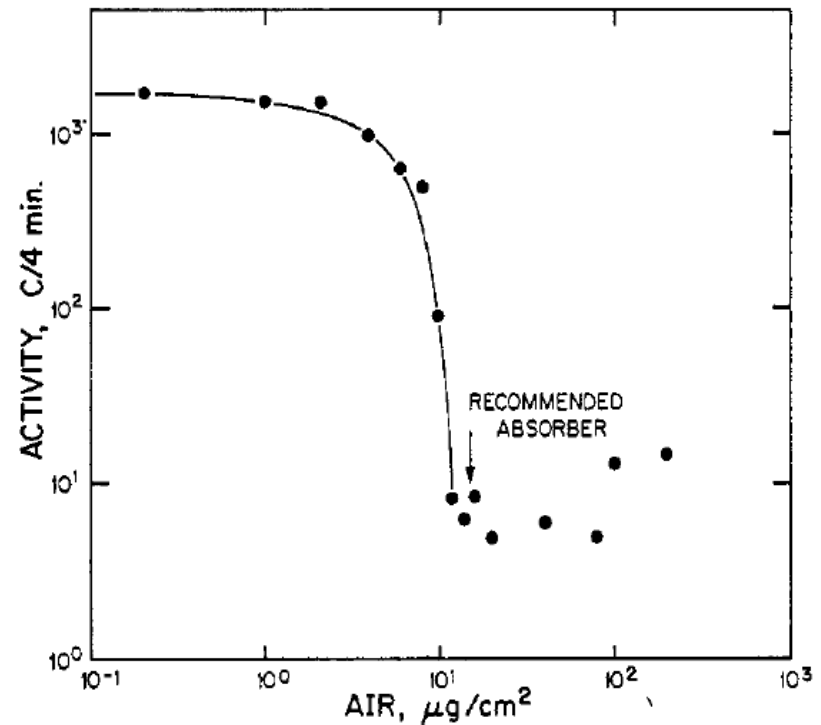

Figure 14. Decrease in recoil contamination of ^{221}Fr with increasing air pressure

Recoil Contamination

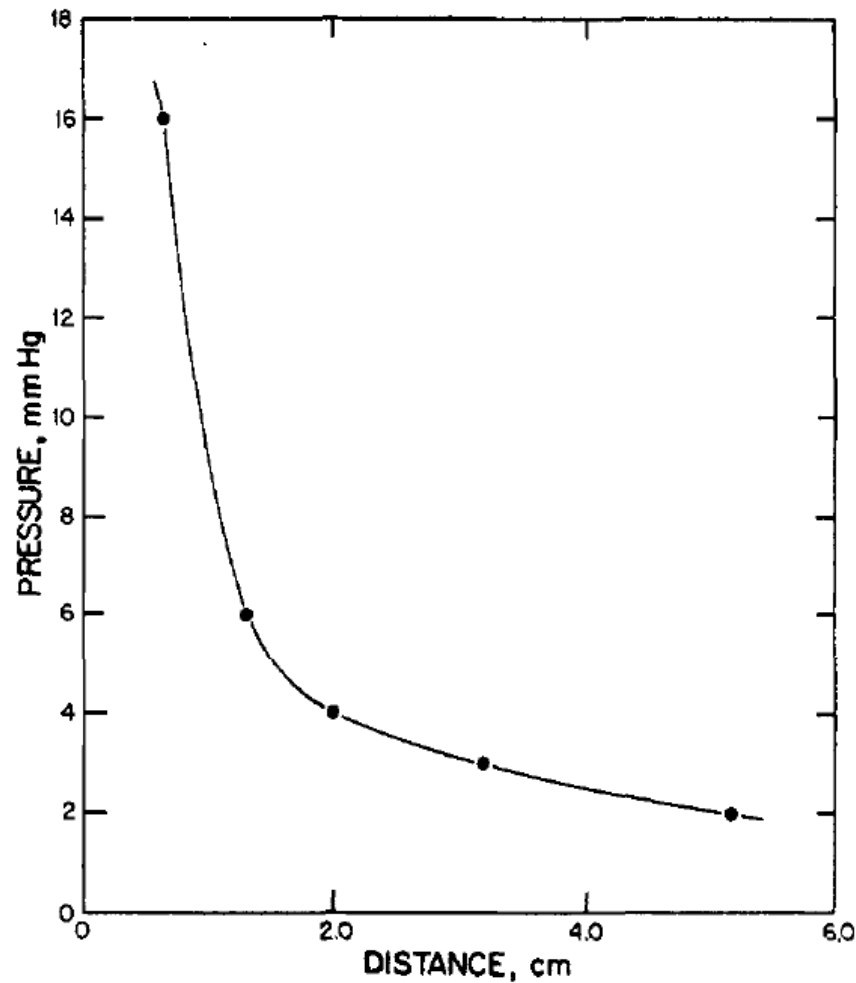

Figure 15. Pressure required to stop recoiling ^{221}Fr atoms at various source-to-detector distances

Source: Sill C.W., Olsen D.G., *Sources and prevention of recoil contamination of solid state alpha detectors*, Analytical Chemistry **42**, 1596 (1970)

Long-term Stability

- Long-term stability of detectors is important due to the extended count times.
- Surface barrier detectors.
 - Sensitive surface
 - Easily affected by oil or acid vapors, fingerprints
- Passivated ion-implanted planar detectors.
 - More rugged
 - Can be cleaned with isopropanol

Long-term Stability

- All alpha detectors are sensitive to light.
- Detectors are also sensitive to temperature changes.
 - An increase in temperature leads to an increase in leakage current
 - Doubles every 5.5 – 7.5 °C

Sample Processing

- Sample preparation is required to convert the raw sample into a form that is suitable for alpha spectrometry.
- The goal of this process is to:
 - Remove elements with interfering alpha energies
 - Remove elements that produce radiochemical interferences and lower the yield for the analyte
 - Remove interference that would increase the mass of the counting source

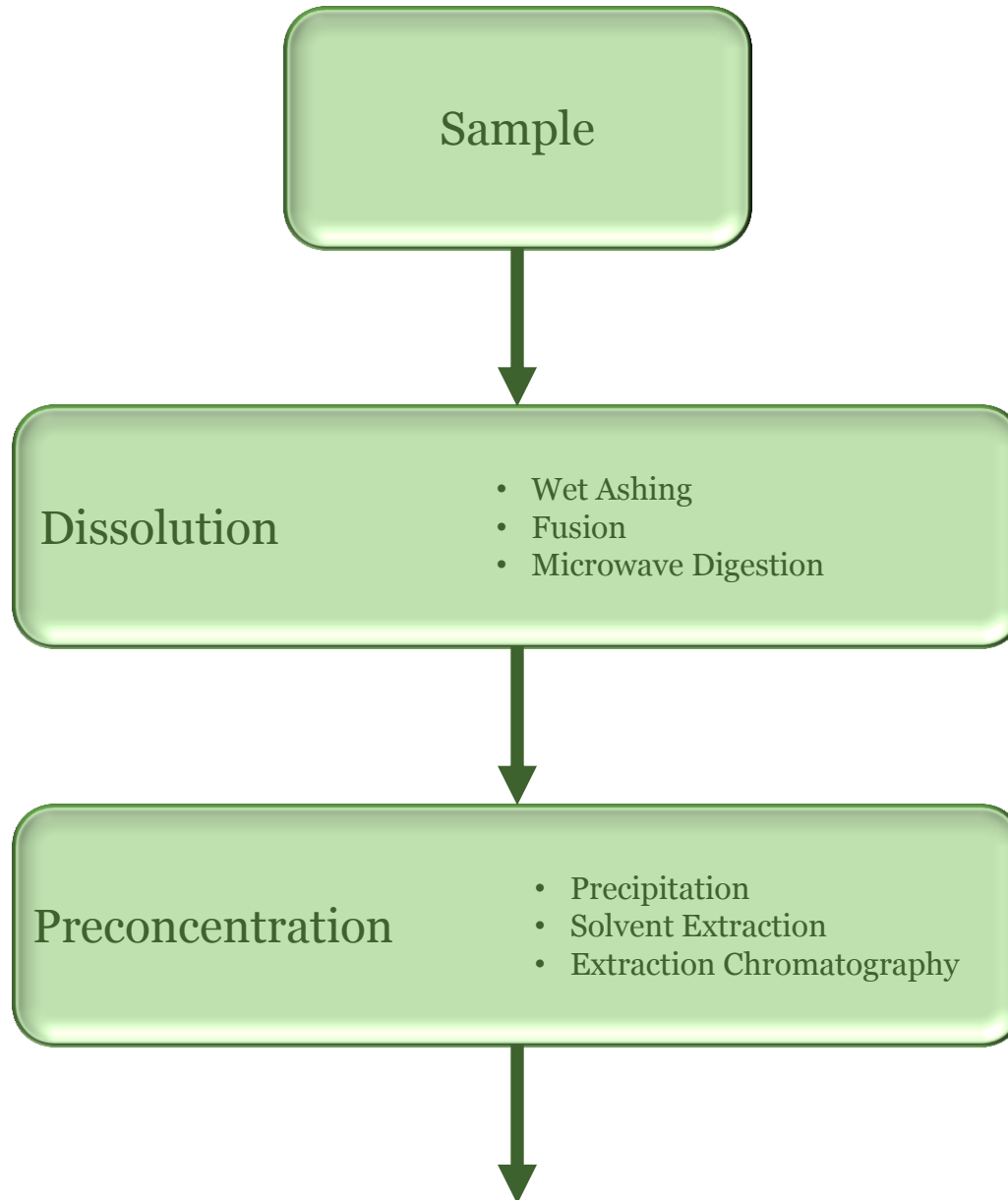

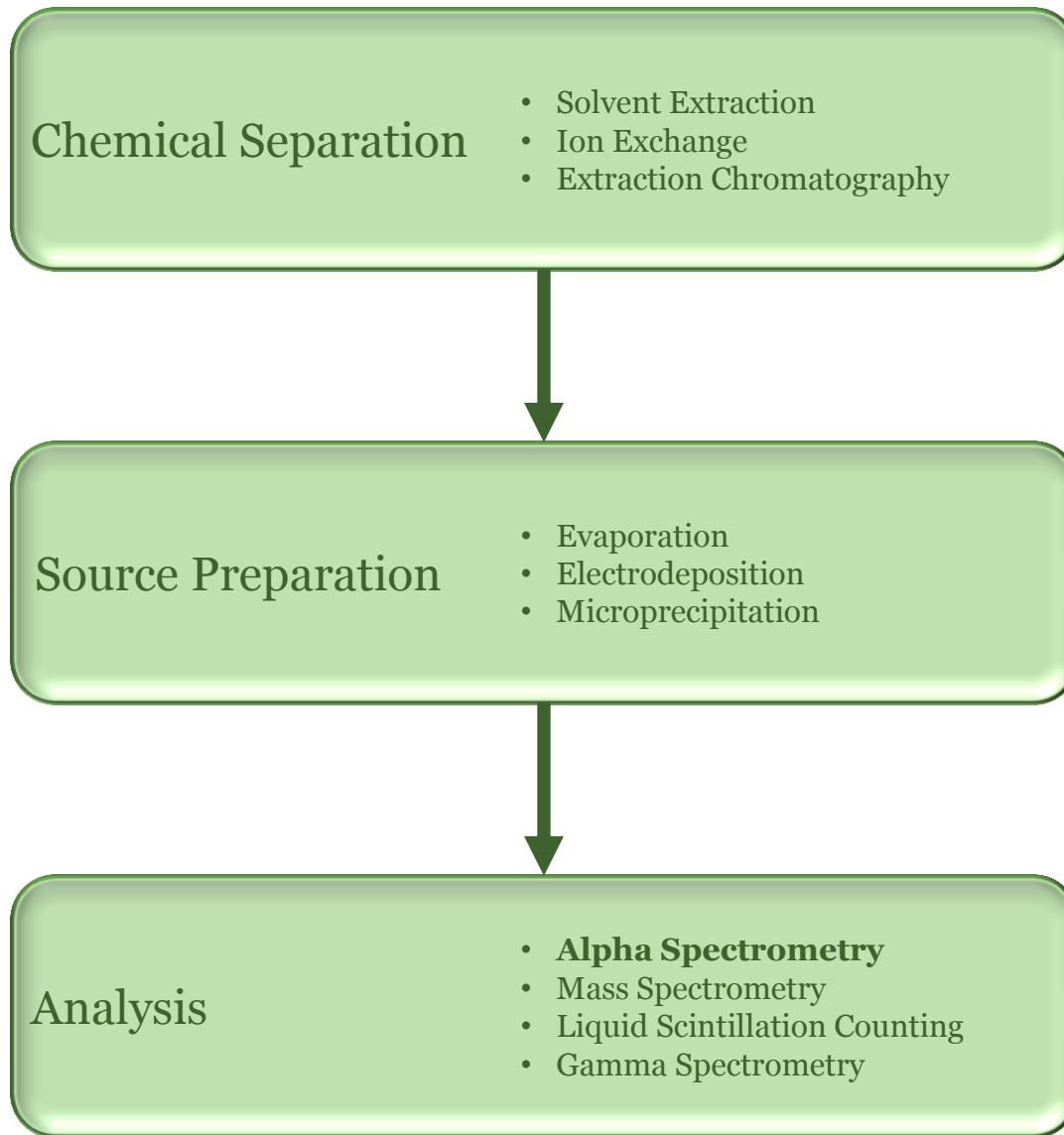

Source Preparation

- The ideal source for alpha spectrometry would be an infinitely thin, weightless source on a perfectly flat substrate.
 - This would allow to achieve the highest resolution
- However, this ideal is unlikely to be achieved for real-life environmental samples.
- The presence of inactive contaminants will lead to energy loss by self-absorption, with resulting poor resolution.

Source Preparation Techniques

- Evaporation
 - Aqueous solution
 - Organic solvent
- Electrodeposition
 - Aqueous solution
 - Organic solution
 - Molecular plating
- Co- (Micro-) precipitation
 - Fluoride
 - Hydroxide
- Vacuum sublimation
- Electrospraying

Instrument Calibration

- An instrument calibration has to be carried out to establish:
 - Energy/Channel Relationship
 - Counting Efficiency
 - Energy Resolution (FWHM)

Instrument Calibration

- A multi-nuclide source is typically used as calibration source.
- The source should contain known amounts of 2-4 different radionuclides.
- Nuclides are selected based on the energy region that should be covered.
- Activities of the radionuclides used should be chosen as to minimize instrument dead time.
 - Approximately 100 Bq or less is a typical value

Instrument Calibration

- The distance between source and detector should be larger than the detector diameter.
 - Reduced geometric effect on FWHM
- The sample is then counted long enough to obtain the desired uncertainty.

Calibration Sources

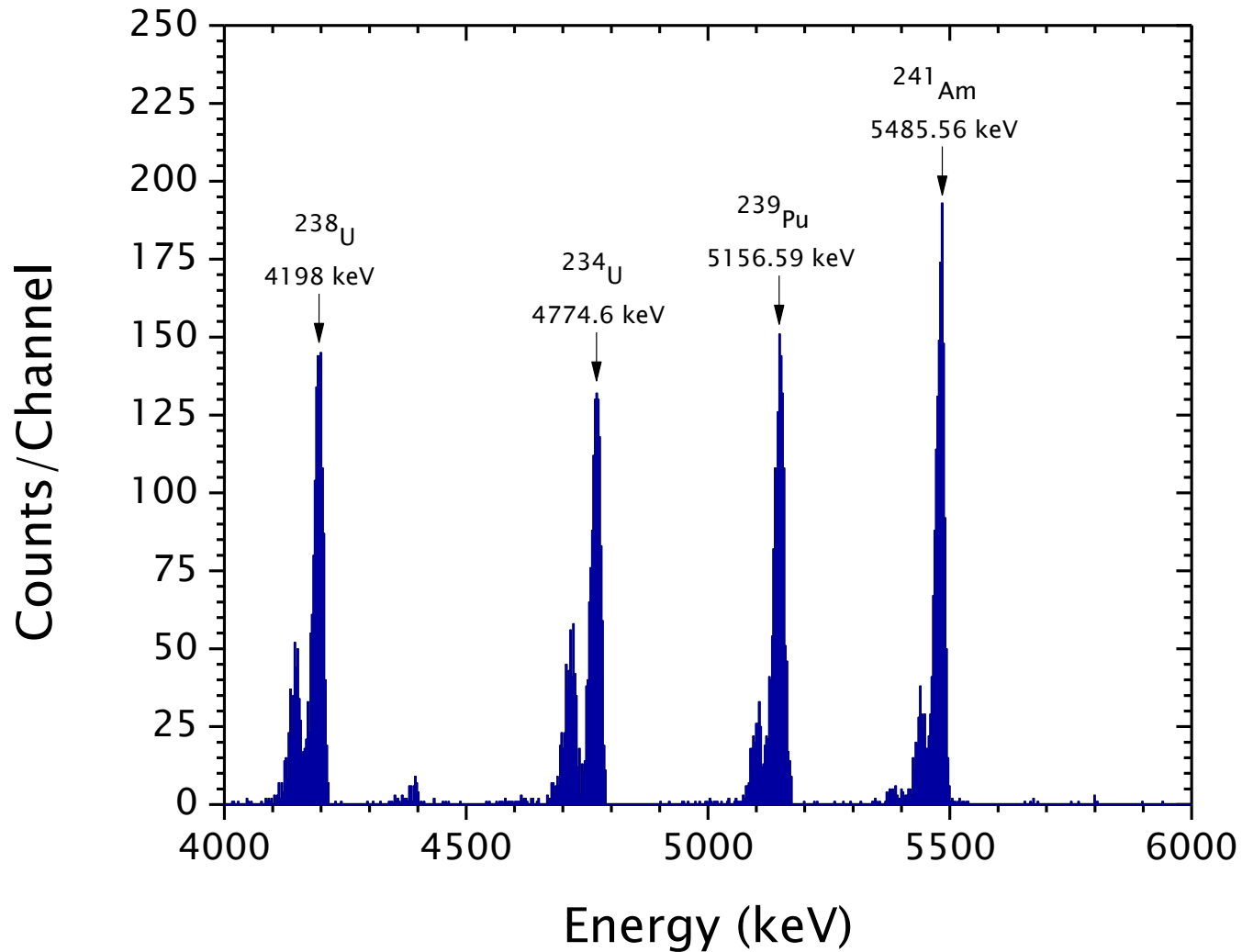

Calibration Sources

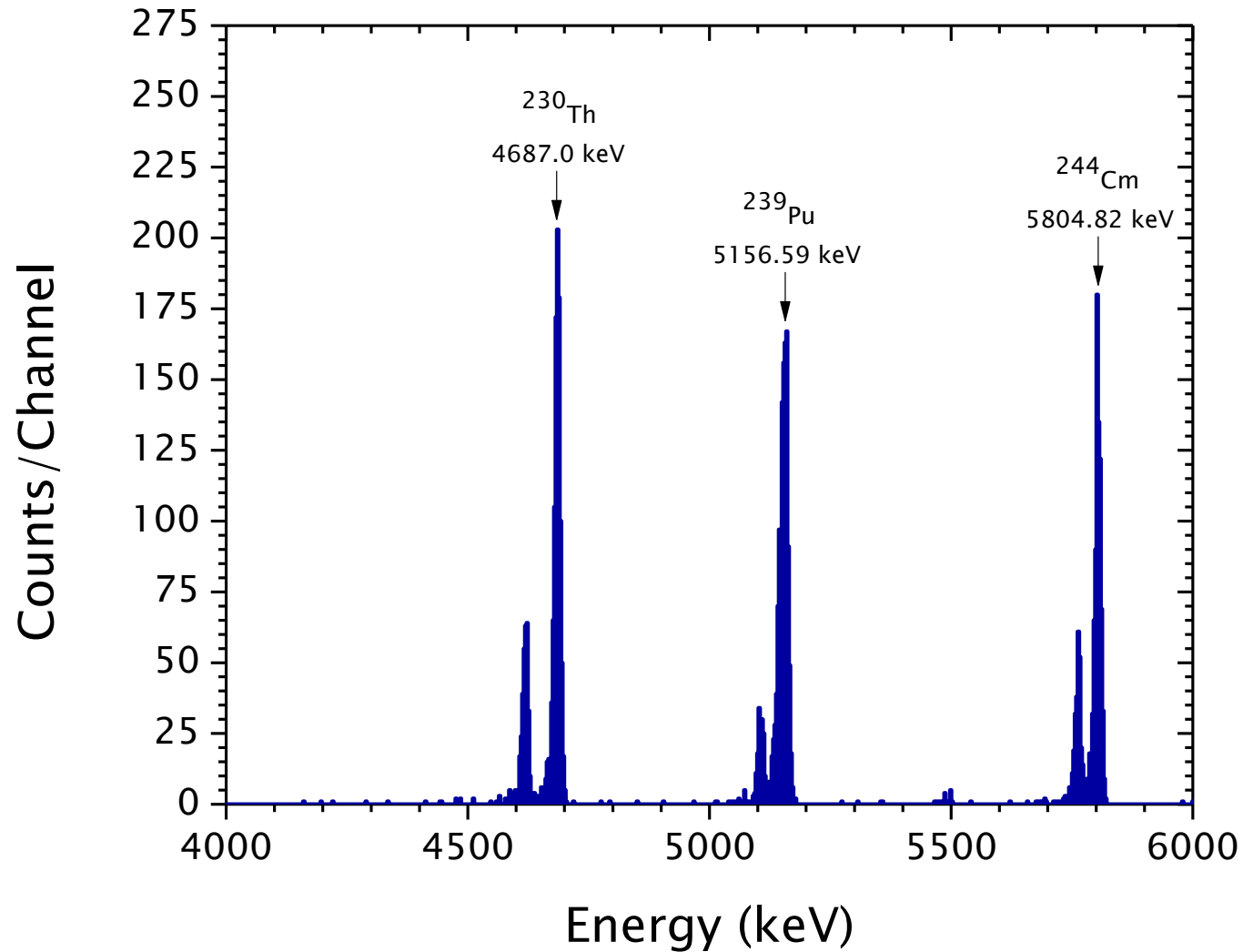

Instrument Calibration

- Energy calibration:
 - The energy of the alpha transition with the highest abundance is plotted against the peak position (channel number)
 - A least-square fit to the data is performed
- Energy Resolution:
 - The peak width is measured at channels corresponding to half of the maximum counts

Instrument Calibration

- Efficiency calibration:
 - The efficiency ε can be determined according to:

$$\varepsilon = \frac{C_{CS} - C_B}{A_S \cdot I_\alpha}$$

where

- C_{CS} = Measured gross count rate of the calibration source
- C_B = Measured background count rate source
- A_S = Decay corrected activity of the calibration source
- I_α = Branching ratio for alpha transition

Sample Measurement

- Sample source is placed at a certain distance from detector.
 - Trade off between efficiency and resolution
- The chamber is evacuated to the desired pressure.
 - About 15 mbar for protection against recoil nuclei
 - About 0.01 mbar for ultra high energy resolution

Sample Measurement

- High voltage is applied to the detector.
 - Between 10 – 100 V depending on detector size
 - Provided by manufacturer
- Measurement time is selected based on detection limit and/or uncertainty required.
 - Environmental samples will need to be counted for days/weeks.

Nuclide Identification

- The sample preprocessing techniques that are used in alpha spectroscopy help to simplify nuclide identification.
- The goal of the chemical separations carried out is to isolate a specific element.
- The fraction used for preparing the counting source should therefore only contain isotopes of the element of interest.

Nuclide Identification

- The energies of the peaks in the spectrum are compared with the literature alpha energy of the expected isotopes.
- An incomplete chemical separation will result in the presence of isotopes from other elements in the spectrum as well.
- Analysis of the spectrum for other nuclides is therefore an important part of method quality control.

Americium

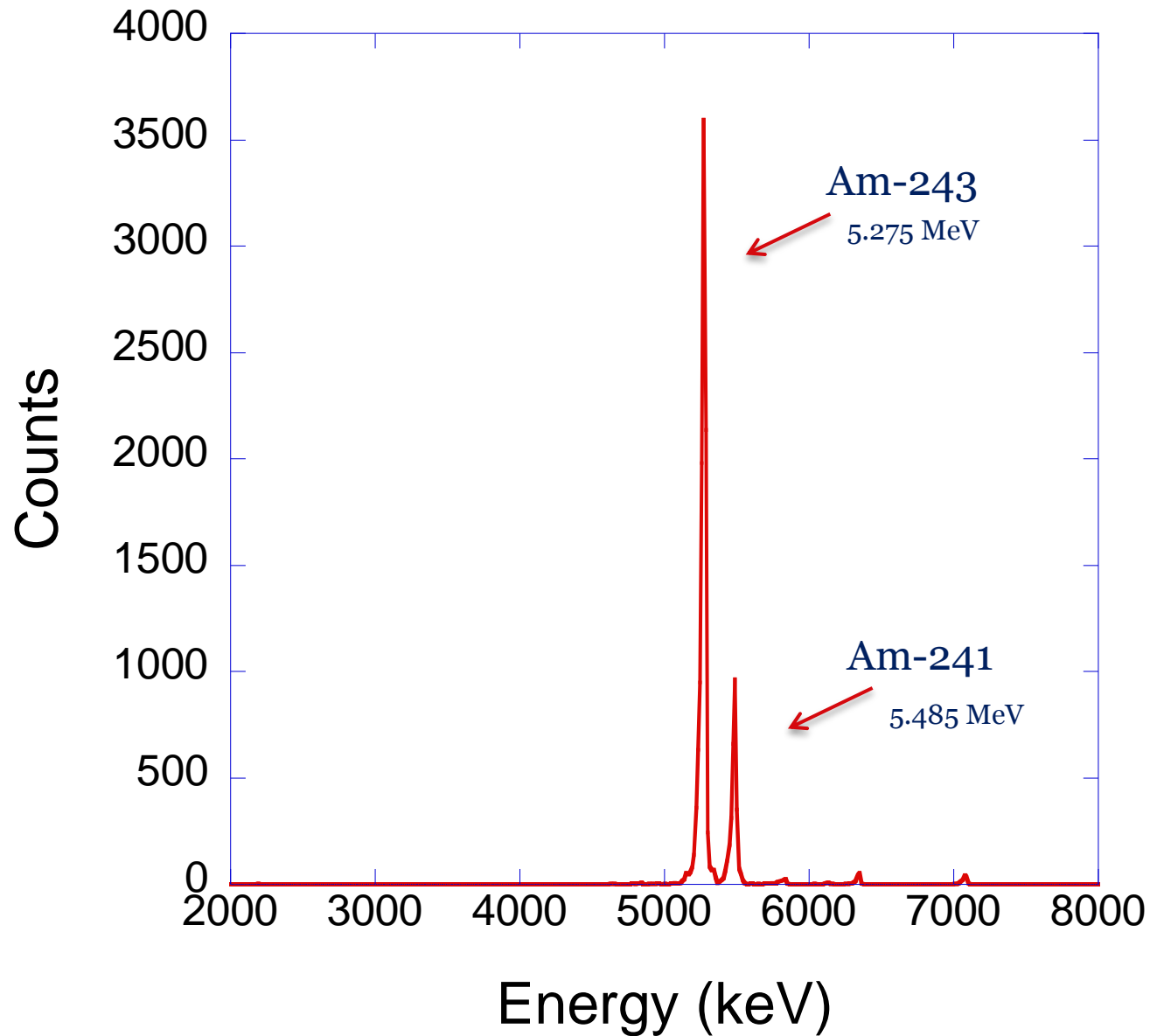

Activity Determination

- The area under the alpha peak of the analyte of interest is determined.
 - Necessary to consider intensities for α transitions
 - Especially important when analyzing for U-235
- A blank sample is used to determine the background counts in the same regions of interest.
 - Blank is typically counted for the same time as the sample
 - Particularly important for uranium analysis

Activity Determination

$$A_S = \frac{C_S - C_B}{\varepsilon \cdot Y_C \cdot I_\alpha \cdot t \cdot V}$$

- where
- A_S = Activity concentration for the analyte of interest
 - C_S = Area under the alpha peak of the analyte
 - C_B = Counts in the ROI of interest for the blank sample
 - ε = Counting efficiency for the tracer
 - Y_C = Chemical yield
 - I_α = Branching ratio for alpha transition
 - t = Measurement time
 - V = Sample volume/mass

U-235 Branching Ratios

E_{α} (keV)	E_{α} (%)
4150	0.9
4214.7	5.7
4219	~0.9
4271	~0.4
4295	~0.009
4366.1	17
4397.8	55
4414	2.1
4435	~0.7
4502	1.7
4556	4.2
4596.4	5.0

Isotope Dilution Analysis

- Determining sample activity requires knowledge of detector efficiency as well as chemical yield.
- The detector efficiency can be determined as part of the instrument calibration.
- In many cases, however, the chemical yield is not known.
 - Recovery can vary significantly between samples
- This can be solved through the use of isotope dilution analysis (IDA).

Isotope Dilution Analysis

- In IDA, a known amount of a radioactive tracer is added to the sample.
 - Tracer should be added as early during sample processing as possible
- The tracer is typically an isotope of the analyte of interest that should not be present in the sample.
 - Tracer and analyte will exhibit the same chemical properties, therefore all losses will be equal
 - **Caution: Both need to be in the same chemical form!**

Plutonium

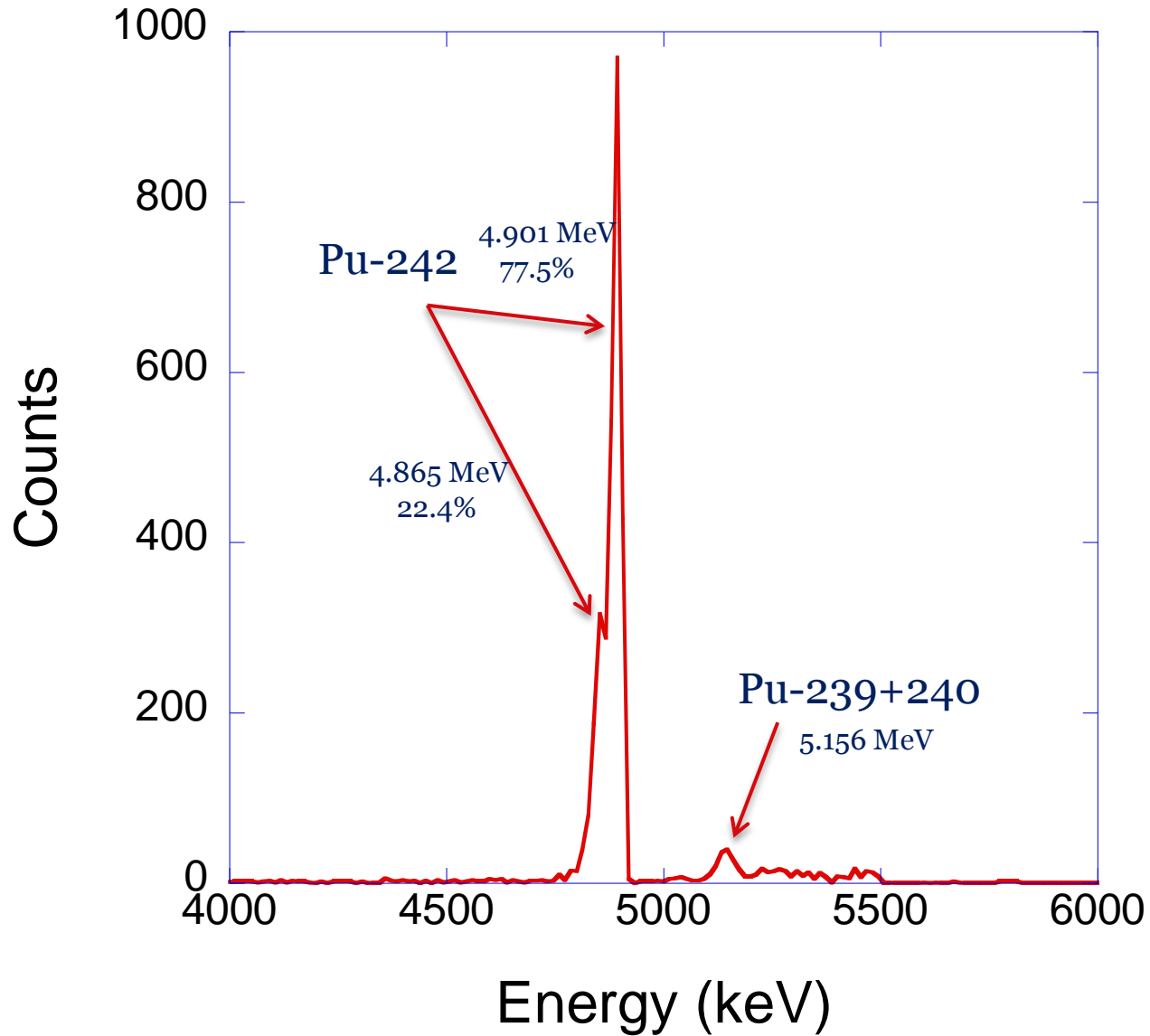

Peak Area Determination

- The area under the alpha peak of the analyte of interest is determined.
- The area under the alpha peak of the corresponding tracer is integrated.
 - Use regions of interest with the same width
- A blank sample is used to determine the background counts in the same regions of interest.

Isotope Dilution Analysis

- The recovery R is given by:

$$R = Y_C \cdot \varepsilon = \frac{C_T - C_B}{A_T \cdot I_\alpha}$$

where

Y_C = Chemical yield

ε = Counting efficiency for the tracer

C_T = Measured gross count rate of the tracer

C_B = Measured background count rate source

A_T = Decay corrected activity of the tracer

I_α = Branching ratio for alpha transition

Isotope Dilution Analysis

- The activity concentration A_S for each analyte can be obtained as:

$$A_S = \frac{C_S - C_B}{R \cdot V}$$

where C_S = Measured gross count rate of the analyte

C_B = Measured background count rate

R = Recovery

V = Sample volume/mass

Tracers

- Factors to consider for tracer selection:
 - Half-life
 - Short: Frequent purification required
Loss during analytical procedure
 - Long: Insufficient specific activity
 - Decay mode
 - Interferences
 - Decay energy
 - Availability and cost

Common Tracers

Tracer	Decay Mode	Alpha Energy	Half -life
Po-209	α	4.881 MeV	102 y
Th-229	α	4.687 MeV	7880 y
U-232	α	5.320 MeV	68.9 y
U-236	α	4.494 MeV	$2.34 \cdot 10^7$ y
Pu-236	α	5.768 MeV	2.858 y
Pu-242	α	4.900 MeV	$3.73 \cdot 10^5$ y
Am-243	α	5.275 MeV	7370 y

Thorium

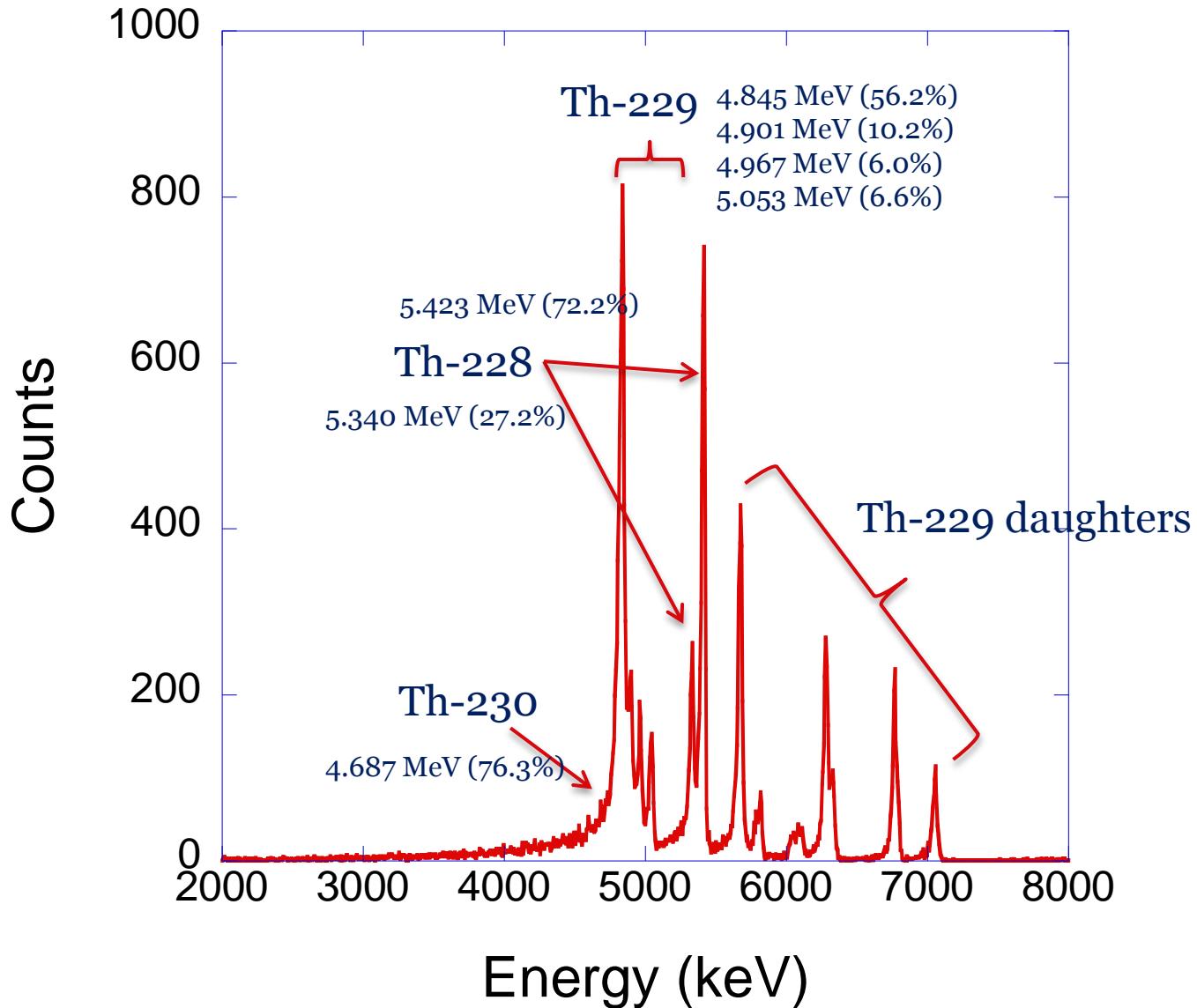

Uranium

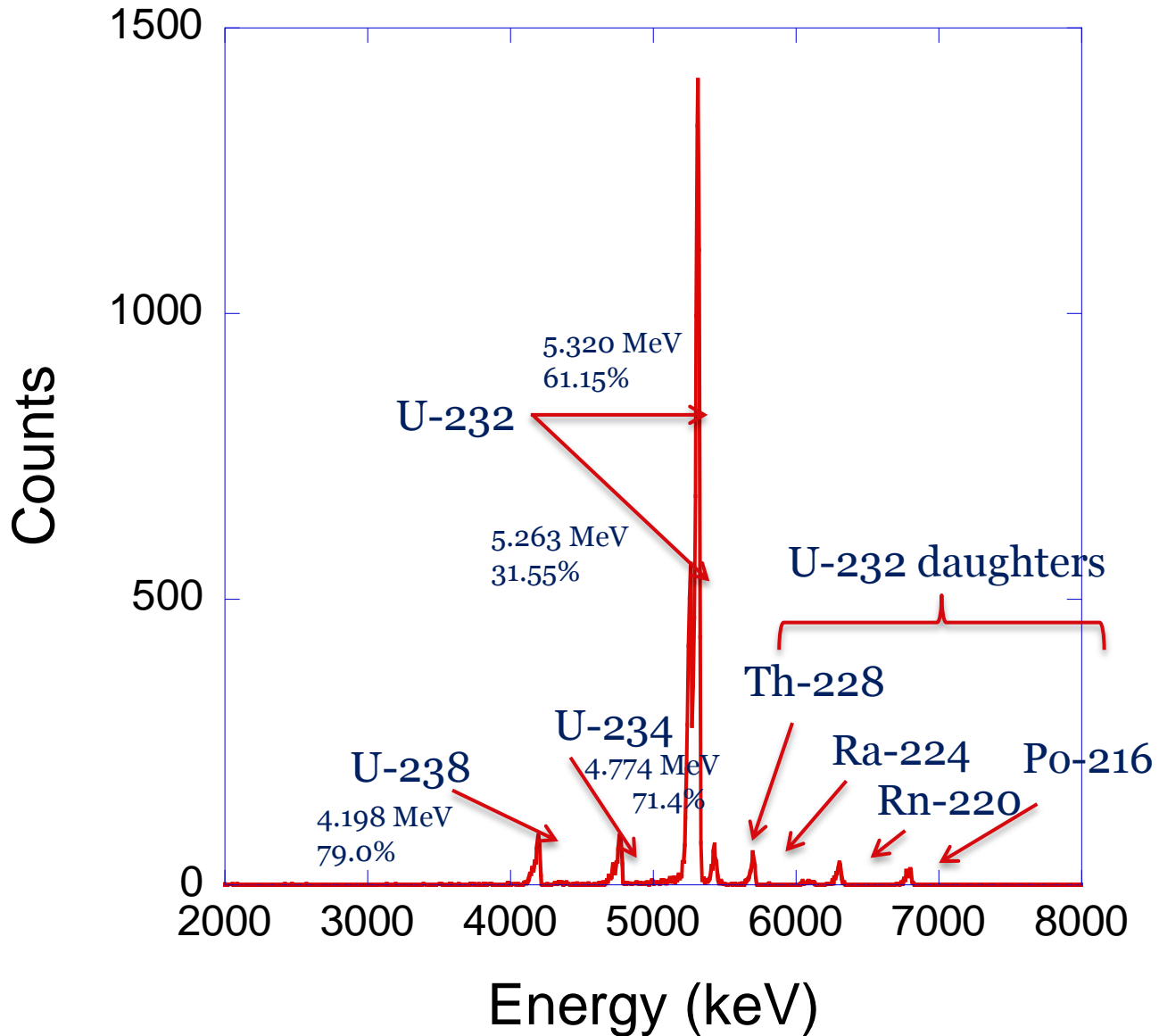

Uranium

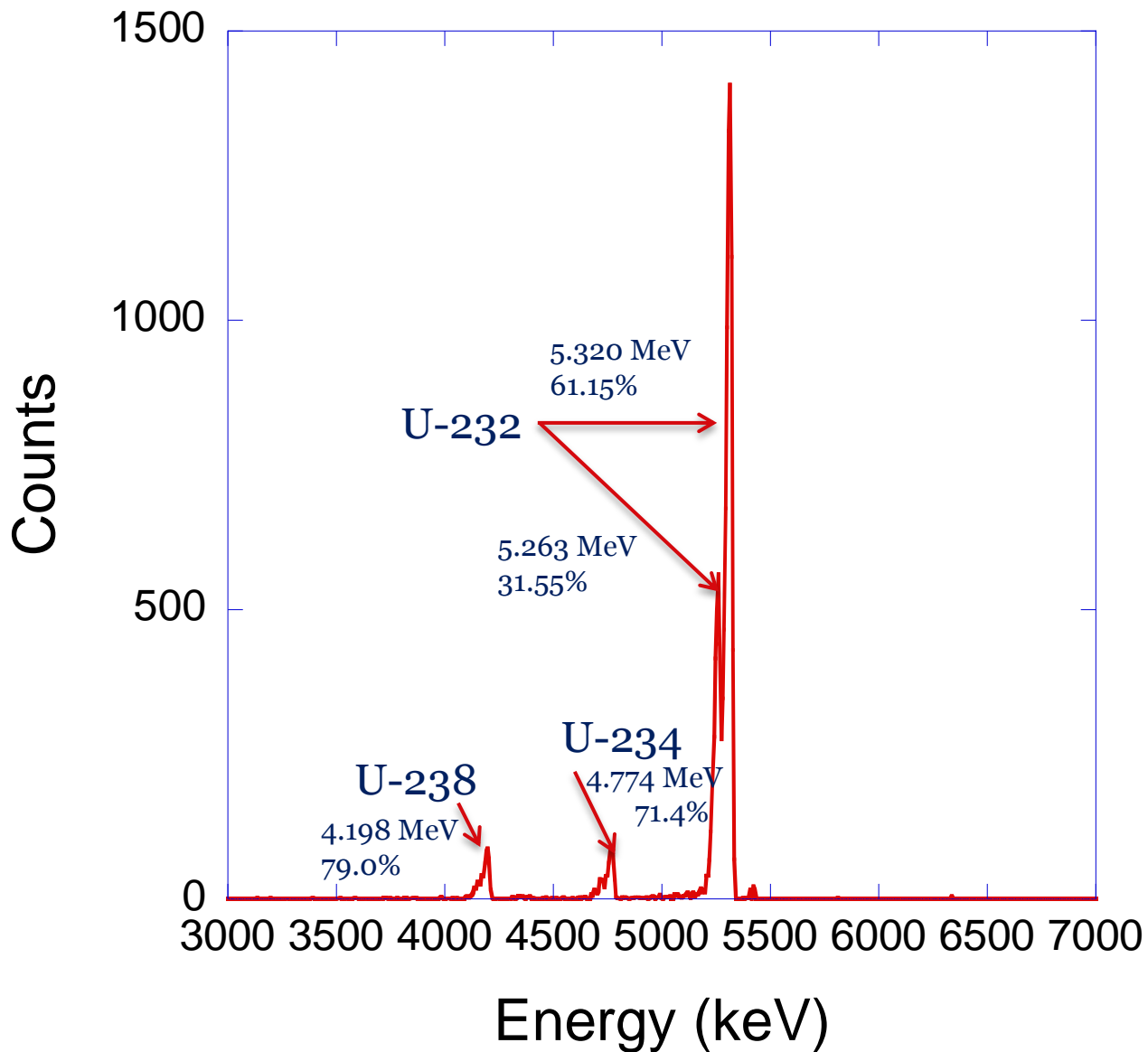

Acknowledgements

- Ms. Mary Turner
- Ms. Sherry Faye

References

1. L'Annunziata, M.F., Handbook of Radioactivity Analysis, 2nd Edition, Academic Press (2003)
2. L'Annunziata, M.F., Handbook of Radioactivity Analysis, 3rd Edition, Academic Press (2012)
3. MARLAP, *Multi-Agency Radiological Laboratory Analytical Protocols Manual*, NUREG-1576 (2004)

Upcoming NAMP Radiochemistry Webinars

- Applications of Liquid Scintillation Counting – May 22, 2014
- Unconventional Drilling/Hydraulic Fracturing and Natural Radioactivity – June 5, 2014
- Introduction to the Fuel Cycle – June 26, 2014

Visit the NAMP website at www.wipp.energy.gov/namp